



Exam : 350-030

Title : CCIE Voice Written

Ver : 08.01.07

QUESTION 1:

When using an Inline-Power enabled Catalyst Switch, which pins are used to supply Inline-Power to an IP Phone?

- A. Pins 1, 2, 3, and 6
- B. Pins 1, 2, 5, and 6
- C. Pins 2, 4, 6, and 8
- D. Pins 3, 4, 7, and 8
- E. Pins 4, 5, 7, and 8

Answer: A

CISCO CATALYST 4000 SERIES SWITCHES, Cisco Catalyst 4000 Series Inline Power Solution

http://www.cisco.com/en/US/products/hw/switches/ps663/products_data_sheet09186a00800924d0.html

QUESTION 2:

When using a Cisco Inline-Power Patch-Panel, which pins are used to supply Inline-Power to the IP Phone?

- A. Pins 1, 2, 3, and 6
- B. Pins 1, 2, 5, and 6
- C. Pins 2, 4, 6, and 8
- D. Pins 3, 4, 7, and 8
- E. Pins 4, 5, 7, and 8

Answer: E

CISCO NETWORK MODULES, Catalyst Inline Power Patch Panel

http://www.cisco.com/en/US/products/hw/modules/ps2797/products_data_sheet09186a00800a9ea3.html

QUESTION 3:

You are a network administrator at Certkiller . Your newly appointed Certkiller trainee wants to know what protocol IP Phone uses to learn the Voice VLAN ID it should use for Voice traffic.

What will your reply be?

- A. Skinny Station Protocol
- B. 802.1q
- C. LLQ
- D. VTP

E. CDP

Answer: E

QUESTION 4:

You are the network administrator at Certkiller . Your newly appointed Certkiller trainee wants to know what MailStore options are supported in Unity version 2.4.6. What will your reply be?

- A. MS Mail
- B. Domino
- C. Exchange 2000
- D. Exchange 5.5
- E. None of the above

Answer: D

http://www.cisco.com/en/US/products/sw/voicesw/ps2237/prod_pre_installation_guide09186a00800ea54b.html
#

QUESTION 5:

You are a network administrator at Certkiller . Certkiller has a Unity3.0/ and Exchange 2000 system. Which of the following attributes will be stored in Active Directory? (Choose three.)

- A. Transfer Type (Supervised, Release to switch)
- B. Location ID
- C. Alternate Extensions
- D. Recorded Name
- E. All of the above

Answer: B, C, D

QUESTION 6:

You are a network administrator at Certkiller . Your newly appointed Certkiller trainee wants to know what Network Management Server (NMS) application she can use to monitor Voice quality by polling the SNMP MIB for MQC. What will your reply be?

- A. Voice Health Monitor
- B. Quality of Service Policy Manager

- C. Internetwork Performance Monitor
- D. Resource Manager Essentials
- E. None of the above

Answer: C

QUESTION 7:

You are the network administrator at Certkiller . The Certkiller network and the complete MPLS router QoS configuration is shown in the following exhibit:

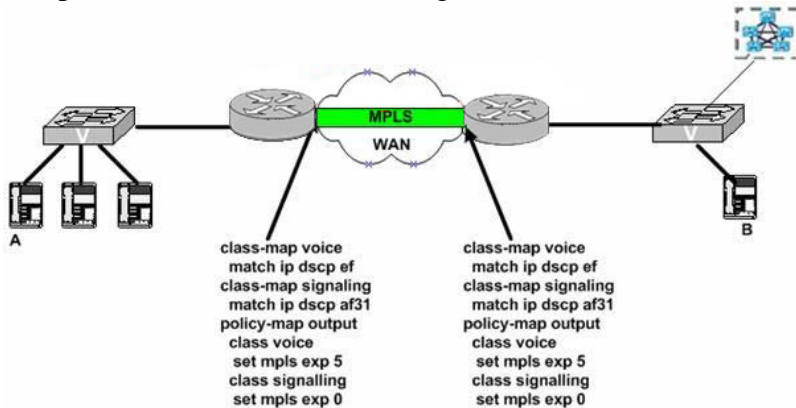

The LAN switches (and any other equipment in the cloud) do not mark or remark the packets.

With regard to the QoS configuration in the exhibit, when IP Phone A calls IP Phone B, how will the voice and signalling packets be marked by the time they arrive at IP Phone B?

- A. Voice: IP Precedence 5; Signaling 3
- B. Voice: DSCP AF ; Signaling : DSCP EF31
- C. Voice: IP Precedence 5; Signaling 3: 0
- D. Voice: DSCP EF; Signaling : DSCP EF31
- E. Voice: DSCP EF; Signaling : 0

Answer: D

The DSCP field remains unchanged in the entire process

QUESTION 8:

You are a network administrator at Certkiller . Your newly appointed Certkiller trainee wants to know what protocol an IP Phone uses to learn the IP Address of its TFTP Server.

What will your reply be?

- A. CDP

- B. OSPF
- C. HSRP
- D. EIGRP
- E. DHCP

Answer: E

QUESTION 9:

With regard to jitter, which of the following statements are true?

A. Jitter is the variation from the time that a packet is expected to be received and when it is actually received.

Voice devices have to compensate for jitter by setting up a playout buffer to accept voice in a smooth fashion and avoid discontinuity in the voice stream.

B. Jitter is the actual delay from the time that a packet is expected to be transmitted and when it actually is transmitted.

Voice devices have to compensate for jitter by setting up a playin buffer to play back voice in a smooth fashion and avoid discontinuity in the voice stream.

C. Jitter is the actual delay from the time that a packet is expected to be transmitted and when it actually is transmitted.

Voice devices have to compensate for jitter by setting up a playout buffer to play back voice in a smooth fashion and avoid discontinuity in the voice stream.

D. Jitter is the variation from the time that a packet is expected to be received and when it is actually received.

Voice devices have to compensate for jitter by setting up a playin buffer to accept voice in a smooth fashion and avoid discontinuity in the voice stream.

Answer: A

QUESTION 10:

You are a network administrator at Certkiller . Your newly appointed Certkiller trainee wants to know what the differences between Type of Service (ToS) and Class of Service (CoS) are.

What will your reply be? (Choose two.)

A. CoS allows a class based access to the media, but ToS prioritizes this access according to the precedence bit.

B. CoS is a field in the IP header, but ToS is evaluated by the routing protocol.

C. CoS is a Layer 2 mechanism, but ToS is a Layer 3 mechanism.

Answer: A, C

Explanation:

CoS Layer 2

<http://www.cisco.com/univercd/cc/td/doc/product/software/ios120/120newft/120limit/120s/120s28/12swred.htm>

ToS Layer 3

http://www.cisco.com/en/US/products/hw/switches/ps672/products_qanda_item09186a00800a8922.shtml

QUESTION 11:

You are a network engineer at Certkiller . The Certkiller network is shown in the following exhibit:

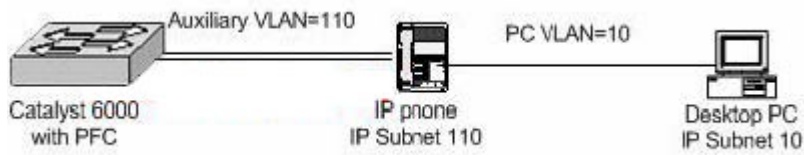

You have just configured the Catalyst 6000 with the following commands:

```
set qos enable
```

```
set port qos 5/1-48 vlan-based
```

```
set port qos 5/1-48 trust-ext untrusted
```

```
set port qos 5/1-48 trust trust-cos
```

We assume that the IP Phone is connected to port 5/1, which of the following statements are true? (Choose three.)

- A. The IP Phone will re-write the CoS of 802.1p/Q-tagged packets from the PC to CoS=0.
- B. The IP phone will not modify the DSCP of packets from the PC.
- C. The Catalyst 6000 will not modify the CoS of any packets received on port 5/1.
- D. The Catalyst 6000 switch port 5/1 will re-write the CoS of all packets received on VLAN 110 with CoS=5.
- E. The Catalyst 6000 switch port 5/1 will re-write all packets with a Cos=0.

Answer: A, B, C

Explanation:

```
set port qos trust
```

http://www.cisco.com/univercd/cc/td/doc/product/lan/cat6000/sw_7_2/cmd_ref/set_po_r.htm#39814

QUESTION 12:

You are the network administrator at Certkiller . The Certkiller network is shown in the following exhibit:

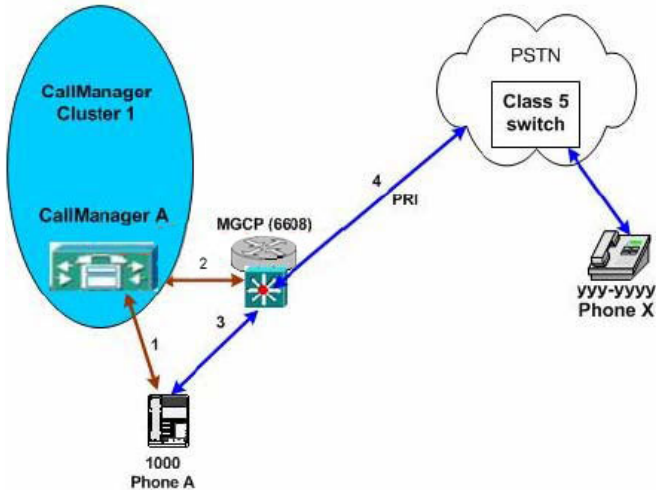

The default gateway in the Certkiller network is a 6608 blade that is running MGCP. Call Manager runs version 3.1. Certkiller users will make calls from Phone A to Phone X. All IP streaming is G.711. Each of the logical links in the Certkiller network carries different types of traffic. On which link can q.921 traffic be sent?

- A. 1 only
- B. 2 and 3
- C. 2 and 4
- D. 3 and 4
- E. 4 only

Answer: E

QUESTION 13:

You are a network administrator at Certkiller . Your newly appointed Certkiller trainee wants to know what the term "MGCP backhaul" means. What will your reply be?

- A. Transporting T1 CAS messaging to the MGCP Call Agent across IP.
- B. Transporting ISDN Q.931 messaging to the MGCP Call Agent across IP.
- C. Transporting ISDN Q.921 messaging to the MGCP Call Agent across IP.
- D. Transporting ISDN Q.931 messaging into MGCP events to the MGCP Call Agent.
- E. Encapsulating ISDN Q.931 CDR records to a RADIUS server.

Answer: B

Explanation:

CISCO IOS SOFTWARE RELEASES 12.2 SPECIAL AND EARLY DEPLOYMENTS
MGCP-Controlled Backhaul of BRI Signaling in Conjunction with Cisco CallManager

http://www.cisco.com/en/US/products/sw/iosswrel/ps5012/products_feature_guide09186a00801a8bc4.html

QUESTION 14:

You are the network administrator at Certkiller . Certkiller has a CM network deployed with MGCP to the branch office GWs. The Certkiller network is shown in the following exhibit:

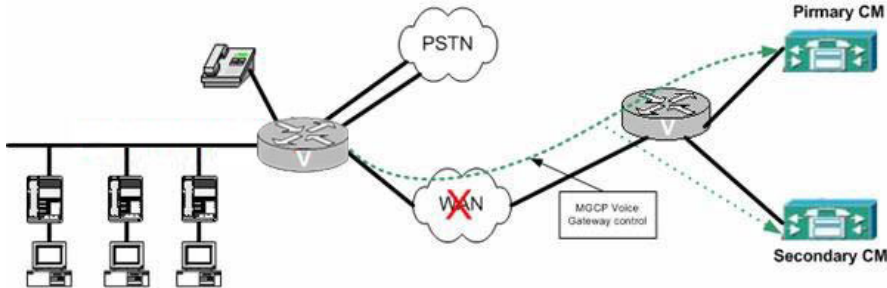

You want to protect the protect branch office telephony (IP phone to IP Phone, and IP Phone to PSTN) in the event of a WAN failure.

Which design methods could you implement? (Choose two.)

- A. SRST
- B. MGCP gateway fallback
- C. CM clustering
- D. Primary and Secondary CMs
- E. CAC

Answer: A, B

QUESTION 15:

You are the network administrator at Certkiller . The Certkiller network is shown in the following exhibit:

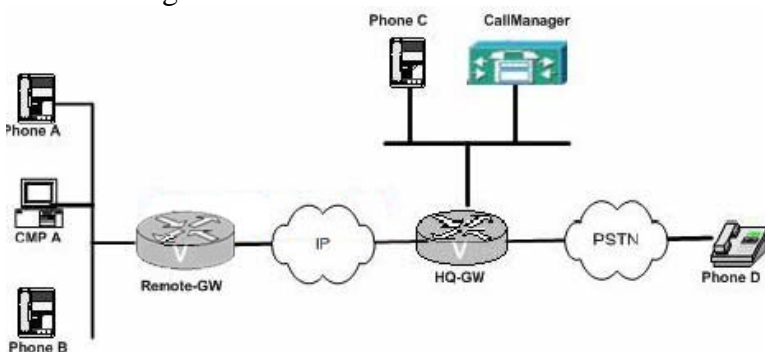

A Certkiller user at PhoneA has finished a call. He later notice that "CM Fallback Service Operating" is displayed on Phone A.

What is the possible cause of this? (Choose two.)

- A. The TCP connection between CallManager and PhoneA has been disrupted.

- B. The FE on HQ-GW is out of service.
- C. The FXO port on Remote-GW is out of service.
- D. The FE on Remote-GW is out of service.
- E. Remote-GW has not received any messages from CallManager within the timeout period.

Answer: A, B

Explanation:

VOICE SOLUTIONS FOR BRANCH/SMALL OFFICE, Highly Available IP Communications White Paper

http://www.cisco.com/en/US/netsol/ns340/ns394/ns346/ns383/net_value_proposition09186a00801c6097.html

The only way a phone will show the message "CM Fallback Service Operating" is if the local GW router's SRST config has become active. If you break the connection from the phone to Call Manager, the router's SRST config will not become active. This message comes from an active SRST router only, so unless the remote gateway goes into SRST active mode, you will not see this message.

QUESTION 16:

You are the network administrator at Certkiller . The Certkiller Voice network is shown in the following exhibit:

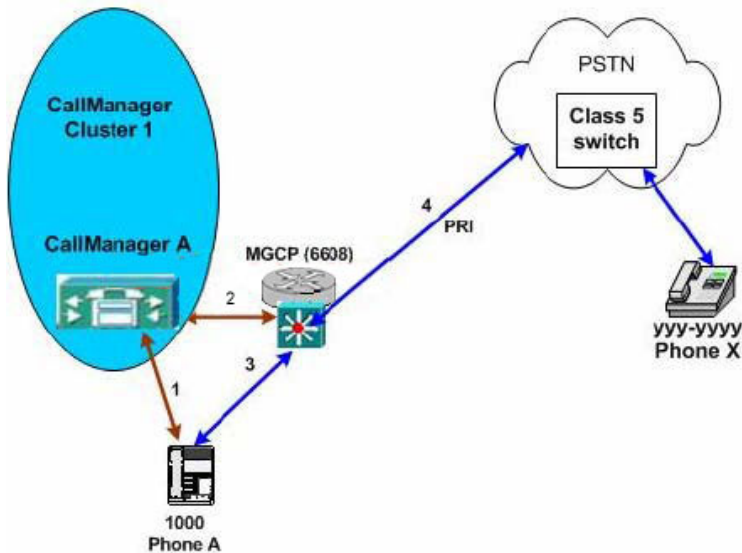

The default gateway in the Certkiller network is a 6608 blade that is running MGCP. Call Manager runs version 3.1. Certkiller users will make calls from Phone A to Phone X. All IP streaming is G.711. Each of the logical links in the Certkiller network carries different types of traffic. On which link can Skinny (SCCP) traffic be seen?

- A. 1 only
- B. 1 and 2

- C. 1, 3, and 4
- D. 2, and 3
- E. 2, 3, and 4

Answer: A
Skinny is only used between CCM and IP phone

QUESTION 17:

On which of the following does the maximum device weight capacity a Cisco MCS server depend? (Choose three.)

- A. The quantity and the type of phones configured on the Cisco MCS server.
- B. CCM software release version.
- C. The amount of memory, CPU and I/O throughput.
- D. The server model and type.

Answer: B, C, D

QUESTION 18:

You are the network administrator at Certkiller . The Certkiller WAN is shown in the following exhibit:

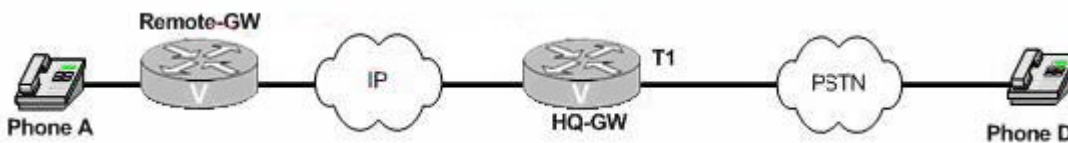

The remote Certkiller user at Analog Phone A tries to make a call to Analog Phone D. The call is rejected. You troubleshoot the problem and discover that the ISDN Plan and Type that the PSTN was receiving was not setup correctly. The PSTN was expecting the following:

Plan: Unknown

Type: Unknown

While the PSTN was receiving the following:

Plan:ISDN

Type: Unknown

Which methods will resolve this problem?

- A. Use the isdn map command on the POTS dialpeer on Remote-GW.
- B. Use the isdn map command on the VOIP dialpeer on HQ-GW.
- C. Use the isdn map command on the POTS dialpeer on HQ-GW.
- D. Implement an outgoing translation rule on the VOIP dialpeer on HQ-GW.
- E. Use the isdn map command on the VOIP dialpeer on Remote-GW.

Answer: D

Explanation:

You can't use ISDN MAP on a VOIP dial-peer.

What we can do is making a translation rule, which can modify the field for the ISDN fields.

Reference: Implementing Cisco Voice Gateways and Gatekeepers Volumes 1 & 2

QUESTION 19:

Migrating from TDM voice requirements to VoIP usually does not cause migration issues for customers who expect to be:

- A. Deploying in a Green-Field scenario.
- B. Fully IP in 1 to 3 years.
- C. Fully IP within 12 months.
- D. All of the above.

Answer: A

QUESTION 20:

You are the network administrator at Certkiller . The Certkiller network is shown in the following exhibit:

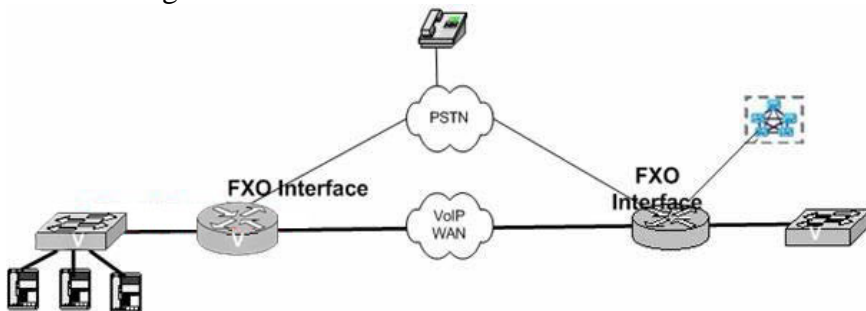

You want to implement Caller ID for calls from PSTN to the IP Phones. Analog trunks are equipped to the PSTN from both the GWs. The PSTN CO switch is capable of delivering Caller ID on the connection to the Cisco voice GW. The Cisco voice gateway is using a VIC-2FXO-M1 card.

What would be the correct voice GW design?

- A. None. Caller ID is not supported on analog FXO.
- B. GW connected via SCCP to the CallManager.
- C. GW must be a 2600/3600/3700 series platform.
- D. GW connected via MGCP to the CallManager.
- E. GW connected via H.323 to the CallManager.

Answer: E

QUESTION 21:

You are a network administrator at Certkiller . Certkiller has recently joined a ISP that offers debit card calling from the US to other locations around the world where they only have FXO connectivity to the PSTN. The Certkiller network is shown in the following exhibit:

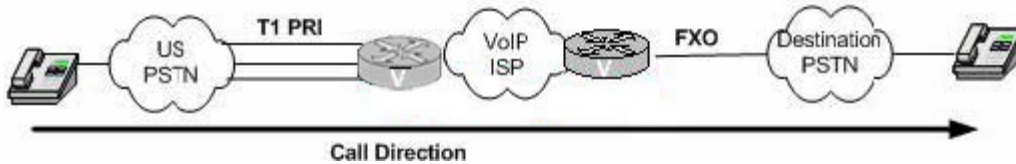

It is crucial to the ISP to ensure that their consumers are not charged for the call unless the call successfully reached the called party in the PSTN.

Which of the following design requirements will achieve the ISP's desired results?

- A. Use Voice Activity Detection (VAD) to determine whether or not a person answered the call.
- B. Use CDR records to determine which calls resulted in "ring no answer" and which calls were answered.
- C. Configure call progress tone detection on the FXO interface to indicate disconnect supervision.
- D. Avoid use of FXO for this application.
- E. Configure call progress tone detection on the FXO interface to indicate answer supervision.

Answer: E

QUESTION 22:

You are the network administrator at Certkiller . The Certkiller network is shown in the following exhibit:

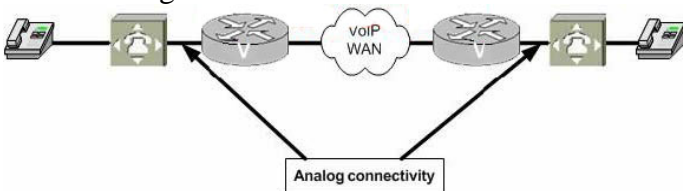

You want Caller ID be displayed for all phones connected to the PBXs, as well as for calls going in both directions across the IP network. The PBXs only have analog (FXS, FXO and E&M) capabilities to connect to the Cisco voice GWs.

What design will satisfy this requirement?

- A. All of FXS, FXO and E&M, provided that the FXO cards support Caller ID.

- B. 2-wire and 4-wire E&M.
- C. 4-wire E&M and FXO.
- D. FXS and E&M only.
- E. None with only analog capability.

Answer: A

QUESTION 23:

Your newly appointed Certkiller trainee wants to know what type of signaling can provide automatic Number Identifications (ANI) on a T1/E1 line. What will your reply be? Select two.

- A. E&M-fgd
- B. Loop Start
- C. PRI
- D. E&M-fgb

Answer: A, C

Explanation:

TELEPHONY SIGNALING, Understanding How Digital T1 CAS (Robbed Bit Signaling) Works in IOS Gateways

http://www.cisco.com/en/US/tech/CK652/CK653/technologies_tech_note09186a00800e2560.shtml

QUESTION 24:

You are the network administrator at Certkiller . The Certkiller network is shown in the following exhibit:

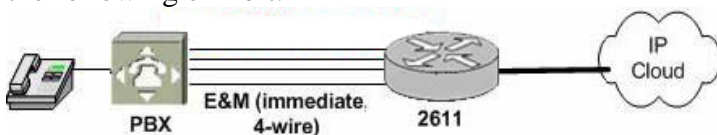

The PBX does not receive the initial few digits from the IP side of the 2611 network. What should you do?

- A. Configure prefix delay, in the dial-peer POTS to add the delay.
- B. Configure interdigit timing 1 under the voice-port.
- C. Configure prefix, in the dial-peer POTS to forward the necessary digits.
- D. Configure delay-dial under the voice-port to add the delay.

Answer: D

Explanation:

TELEPHONY SIGNALING, Understanding and Troubleshooting Analog E&M Start

Dial Supervision Signaling

http://www.cisco.com/en/US/tech/ CK6 52/ CK6 53/technologies_tech_note09186a0080093f61.shtml

QUESTION 25:

You are contracted as a network administrator for a small company, Certkiller Inc. Your newly appointed Certkiller trainee wants to know What settings have to be in place in order to pass hook-flash on h.323 from FXS to FXO:
What will your reply be?

- A. connection trunk must be configured on the voice-port (FXS) and (FXO)
- B. connection plar must be configured on the voice-port (FXS)
- C. connection trunk must be configured on the voice-port (FXS) and (FXO)
- D. connection plar must be configured on the voice-port (FXS) and (FXO)

Answer: D

Explanation:

IP TELEPHONY / VOIP, Configuring Hookflash Relay on FXS/FXO Voice Ports The Following link will provide you with information on IP TELEPHONY / VOIP, Configuring hookflash Relay onFXS/FXO Voice Ports
http://www.cisco.com/en/US/tech/ CK6 52/ CK7 01/technologies_configuration_example09186a008009431b.shtml

QUESTION 26:

Which of the following is the best configuration for provisioning for VoIP at the WAN Edge?

```
A. !
version 12.2
!
class-map match-all VOICE
match ip rtp 16384 32767
class-map match-all VOICE-CONTROL
match protocol skinny
!
policy-map WAN-EDGE
class VOICE
low-latency queuing 33 percent
class class-default
weighted-fair-queue
!
```

B. !
version 12.2
!
class-map match-all VOICE
match ip dscp ef
class-map match-all VOICE-CONTROL
match ip dscp af31
!
policy-map WAN-EDGE
class VOICE
priority percent 33
class VOICE-CONTROL
bandwidth percent 2
class class-default
fair-queue

!
C. !
version 12.2
!
class-map match-all VOICE
match ip dscp 5
class-map match-all VOICE-CONTROL
match ip dscp 3
!
policy-map WAN-EDGE
class VOICE
priority queue percent 33
class VOICE-CONTROL
bandwidth queue percent 2
class class-default
fair-queue

!
D. !
version 12.2
!
class-map match-all VOICE
match ip dscp 46
class-map match-all VOICE-CONTROL
match ip dscp 26
!
policy-map WAN-EDGE
class VOICE
priority 33 percent
class VOICE-CONTROL
bandwidth 2 percent
class class-default

fair-queue
!

Answer: B

QUESTION 27:

You are a network administrator at Certkiller . Certkiller has a Cisco voice gateway that will be connected to a PBX/PSTN-switch via ISDN (PRI, QSIG, BRI). Which attributes of the PBX/PSTN-switch must you know to understand which features to configure on the voice GW in order to connect successfully to the PBX/PSTN-switch? (Choose two.)

- A. Whether Q.921 or Q.931 is supported by the PBX/PSTN-switch.
- B. Whether H.225 or H.323 is supported by the PBX/PSTN-switch.
- C. Whether symmetric mode is supported by the PBX/PSTN-switch.
- D. What PRI/BRI switch-type is supported by the PBX/PSTN-switch.
- E. Whether the network or users side is supported by the PBX/PSTN-switch.

Answer: D, E

QUESTION 28:

Which of the following statements is an attribute of ISDN Non-Facility Associated Signaling (NFAS)?

- A. Enables the D-channel to transmit "data" information unrelated to any voice call, such as inter-switch status updates.
- B. Applicable to voice calls and PRI only, but not data PRI calls.
- C. Is available on both T1 and E1 PRIs.
- D. Single D-channel controls B-channels on the same T1 span, as well on other T1-spans.
- E. Single T1 span can be split into two "trunk groups", each with its own dedicated D-channel.

Answer: D

Voice Enabling the Data Network; Durkin: Cisco Press p124

QUESTION 29:

You are a network administrator at Certkiller , Inc. Certkiller runs a centralized Automatic Message Accounting (CAMA) trunk that allows enterprise voice GW connectivity to the North American (911) services of the PSTN.

A newly appointed Certkiller trainee wants to know what the difference between

CAMA trunk signalling and FXO trunk signalling are.
What will your reply be?

- A. They do not differ in basic signaling, but CAMA is used exclusively for 911 calls, while FXO is used for general PSTN calls.
- B. FXO allows for dialed digit delivery, while CAMA does not.
- C. CAMA provides for dialed digit delivery, while FXO does not.
- D. CAMA provides for ANI digit delivery, while FXO does not.
- E. CAM supports only loopstart, while FXO supports ground- and loopstart.

Answer: A
CIPT Solution Reference Network Design 6-3

QUESTION 30:

You are a network administrator at Certkiller . Your newly appointed Certkiller trainee wants to know how much Layer 3 is required for Call Control on an IP Phone on average.
What will your reply be?

- A. 2 kbps
- B. 8 bps
- C. 16 kbps
- D. 120 bps
- E. 150 kbps

Answer: B
The answer should be 8Kbps

<i>Table Recommended Bandwidth for Call Control Traffic With and Without Signaling Encryption</i>		
Branch Office Size (Number of IP Phones and Gateways)	Recommended Bandwidth for Control Traffic (no encryption)	Recommended Bandwidth for Control Traffic (with encryption)
1 to 10	8 kbps	8 kbps
20	8 kbps	9 kbps
30	8 kbps	13 kbps
40	11 kbps	17 kbps
50	14 kbps	21 kbps
60	16 kbps	25 kbps
70	19 kbps	29 kbps

QUESTION 31:

With regard to Analog DID connections to the PSTN, which of the following statements about are true? (Select two.)

- A.DID trunks can only send calls from the CO.
- B.DNIS information is send out-of-band.
- C.DID trunks can only send calls towards the CO.
- D.DNIS information is send in-band.

Answer: A, B

Explanation: DNIS information is send in a setup message containing all the digits necessary to fully route a call.

QUESTION 32:

Supplementary Services in ISDN for Echo. (Select two.)

- A.) G.711
- B.) H.323
- C.) G.165
- D.) G.174
- E.) G.168

Answer: C, E

The echo canceller complies with ITU-T standards G.164, G.165, and G.168.

QUESTION 33:

Queuing technology in Voice Configurations at the edge gateway (design guide) Voice (RTP-Traffic), Signaling and normal data traffic.

- A.) PQ, CBWFQ, FQ
- B.) LLQ, CBWFQ, WFQ
- C.) LLQ, CBWFQ, FQ
- D.) PQ, WFQ, FQ

Answer: B

Explanation: Data traffic is served in a Weighted Fair Queue strategy.

QUESTION 34:

A newly appointed Certkiller trainee wants to know what protocol that H.255

utilizes a scaled-down version of is also used to set up the connection between two H.323 endpoints.

What will your reply be?

- A. SS7
- B. Q.921
- C. Q.931
- D. H.323
- E. H.245

Answer: C

QUESTION 35:

What are the most important functions of H.245? (Choose two.)

- A. It allows both sides of the call to perform IP address exchange and UDP port negotiations.
- B. It provides Coder/Decoder (CODEC) type negotiation such as G.711, between the calling and the called parties.
- C. It allows both sides of the call to perform IP port negotiation.
- D. It allows both sides of the call to perform H.255 port negotiation.

Answer: A, B

Explanation:

Not C: C is not valid because it does not exist IP ports.

QUESTION 36:

TCP receives a request to open a voice channel on port 1720 in a VoIP network. There is no Fast Start. For what purpose will a new TCP port automatically be allocated for?

- A. H.225 call compression.
- B. H.323 call compression.
- C. G.726 call compression.
- D. H.225 call setup negotiation
- E. H.323 call setup negotiation.
- F. H.245 capability exchange negotiation

Answer: D

QUESTION 37:

You are a network administrator at Certkiller and your newly appointed Certkiller trainee wants to know from you what is considered to be a node on a H.323 network?

What will your reply be?

- A. Proxy.
- B. Gateway.
- C. Gatekeeper.
- D. All of the above.

Answer: D

QUESTION 38:

What is the sampling rate used by PCM as specified by Nyquist?

- A. 800 per second
- B. 1600 per second
- C. 4000 per second
- D. 8000 per second

Answer: D

Cisco Voice over Frame Relay, ATM & IP; Mc Querry; Cisco Press p57

QUESTION 39:

What happens when you use the Low Latency Queuing feature of the Cisco IOS? (Select two.)

- A. All the data traffic is serviced by the PQ.
- B. All the RTP traffic is serviced by the PQ.
- C. All the RTP traffic is serviced by the CBWFQ.
- D. All the data traffic is serviced using the CBWFQ.
- E. None of the above.

Answer: B, D

QUESTION 40:

Your newly appointed Certkiller trainee wants to know what percent of a standard G.711 packet is taken by IP, UDP and RTP headers when CRTP is not used.

What will your reply be?

- A. 15%
- B. 20%
- C. 25%
- D. 33%
- E. 45%

Answer: B

G711 payload is 160 bytes and IP; UPD & RTP headers total 40 bytes

QUESTION 41:

You are the technician at Certkiller . Your newly appointed Certkiller trainee wants to know what command would enable CRTP.

What will your reply be?

- A. ip crtp compress
- B. ip rtp compress stac
- C. ip crtp compress stac
- D. ip rtp header-compression
- E. ip crtp header-compression

Answer: D

To enable Real-Time Transport Protocol (RTP) header compression, use the ip rtp header-compression command in interface configuration mode.

http://www.cisco.com/univercd/cc/td/doc/product/software/ios123/123tcr/123tqr/qos_i1gt.htm#1133081

QUESTION 42:

You are a network administrator at Certkiller . Your newly appointed Certkiller trainee wants to know which fields in the output from show active voice command indicates that packet loss is occurring.

What will your reply be?

- A. The Receive delay field.
- B. The High Water playout delay field.
- C. The Low Water playout delay field.
- D. The Interarrival packet rate field.

Answer: A

VOICE QUALITY, Using the show call active voice Command to Troubleshoot Voice Quality Issues

http://www.cisco.com/en/US/tech/ CK6 52/ CK6 98/technologies_tech_note09186a008019ab88.shtml

QUESTION 43:

What is the default fax relay connection rate?

- A. 14400 bps
- B. 7200 bps
- C. 9600 bps
- D. 28800 bps
- E. 11000 bps

Answer: B

14400 for G711, 7200 for G729. G729 is default codec

QUESTION 44:

Which of the following can AAA NOT be used for? (Choose two.)

- A. Administration
- B. Authentication
- C. Architecture
- D. Admission
- E. Security

Answer: A, C

QUESTION 45:

You are a network administrator at Certkiller . Your newly appointed Certkiller trainee wants to know what the proper configuration for VoIP authentication via Authentication, Authorization, and Accounting (AAA) is.

What will your reply be?

- A. aaa new-model
aaa authentication login voip radius
- B. aaa new-model
aaa authentication login h225 radius
- C. aaa new-model
aaa authentication h323 login radius
- D. aaa new-model
aaa authentication login default radius
- E. aaa new-model
aaa authentication login h323 radius

Answer: A

http://www.cisco.com/univercd/cc/td/doc/product/software/ios123/123cgcr/secur_r/sec_a1g.htm#18239

QUESTION 46:

You are a network administrator at Certkiller . You want to configure an AS5300 to authenticate Certkiller users for Authentication, Authorization, and Accounting (AAA) RADIUS server by prompting the user for a PIN number, etc. You want AS5300 to use application clid_authen_collect. Certkiller users are currently dialing 9592000.

What configuration should you use?

- A. dial-peer voice 1 pots
destination-pattern 9592.....
port 0:D
application clid_authen_collect
- B. dial-peer voice 1 pots
destination-pattern 2.....
port 0:D
application clid_authen_collect
- C. dial-peer voice 1 pots
incoming called number 9592000
destination-pattern 2.....
port 0:D
application clid_authen_collect
- D. dial-peer voice 1 pots
incoming called-number 959....
destination-pattern 2.....
port 0:D
application clid_authen_collect

Answer: D

Cisco IOS Voice Commands, application

http://www.cisco.com/univercd/cc/td/doc/product/software/ios122/122newft/122tcr/122tvr/vrg_a1.htm#149288
1

QUESTION 47:

On what is busy hour traffic for voice gateway port/trunk is based upon in a call center deployment? (Choose two.)

- A. Queue time.
- B. Agent talk time.
- C. Agent wrap up time.

- D. Agent after call work time.
- E. All of the above.

Answer: A, B

QUESTION 48:

You are a network technician at Certkiller . Your newly appointed Certkiller trainee asks you what three elements make up the MQC.
What will your reply be?

- A. Class-map, Policy-map and Service-policy statement
- B. DSP, Codec and Sampling Rate
- C. Mean Opinion Scores, representative sampling, Standard Deviation
- D. Gatekeeper, H 323 Proxy and RSVP
- E. Firewall, Router, Bios

Answer: A

QUESTION 49:

You are a network administrator at Certkiller . You want to configure a T1 (1,536M) FR PVC for voice and data traffic. You do not expect voice to require more than half the bandwidth.
Which of the following would be the most sufficient FRTS configuration?

- A. map-class frame-relay FRST-voice
frame-relay cir 1536000
frame-relay bc 15360
frame-relay be 0
frame-relay mincir 1536000
- B. map-class frame-relay FRTS-voice
frame-relay cir 1536000
frame-relay bc 15360
frame-relay be 0
frame-relay mincir 768000

Answer: B

Explanation: We think that B is the correct answer because frame-relay mincir of 768000 guarantees all the voice traffic in the link due congestion (assuming Voice is correctly placed in the PQ queue)

QUESTION 50:

You are a network administrator at Certkiller . Your newly appointed Certkiller trainee wants to know what is NOT a primary cause of echo in a voice network. What will your reply be?

- A. Delay in the IP Network.
- B. Acoustical Reflections.
- C. 4 wire to 2 wire Hybrids.
- D. Packet Loss in the IP Network.
- E. All of the above.

Answer: D

QUESTION 51:

There are 100 calls with duration of 6 minutes in busy hour time. How many Erlangs is this?

- A.) 100 Erlang
- B.) 10 Erlang
- C.) 3600 CCS, Centum Call Seconds
- D.) B and C

Answer: B

Explanation:

Points of contention:

1. To calculate this the formula for Erlangs is- $1\text{Erlang} = (\text{BCHA} \times \text{AHT}) / 3600$ or $/60$
2. In the above example $[100 (\text{BHCA}) \times 6 \text{ minutes (aht) }] / 60 = 10\text{Erlangs}$
3. [http://www.cisco.com/en/US/partner/tech/ CK6 52/ CK7 01/technologies_white_paper09186a00800d6b74.shtml](http://www.cisco.com/en/US/partner/tech/CK652/CK701/technologies_white_paper09186a00800d6b74.shtml)

One erlang is 3600 seconds of calls on the same circuit, or enough traffic load to keep one circuit busy for 1 hour. Traffic in erlangs is the product of the number of calls times AHT divided by 3600, as shown in the following example:

$(23 \text{ calls} * 172.87 \text{ AHT}) / 3600 = 1.104 \text{ erlangs}$ Which unit you use depends highly on the equipment you use and what unit of measurement they record in. Many switches use CCS because it is easier to work with increments of 100 rather than 3600. Both units are recognized standards in the field. The following is how the two relate: 1 erlang = 36 CCS.

QUESTION 52:

What is the purpose of the Erlang-C Traffic Model in an IP Contact Center

deployment?

- A. To provision ports on an IP-IVR interfacing with Cisco CallManager.
- B. To provision agents initiating/handling the outbound calls only.
- C. To provision agents receiving/handling the inbound calls.
- D. To provision ports on a voice gateway interfacing to the PSTN.

Answer: C

According the website <http://www.erlang.com/whatis.html> , the source given by Cisco as a study resource, the Erlang C is used for Call Center Agent staffing / queuing.

QUESTION 53:

Which of the following can generate 100 Erlangs during the busy hour? (Choose two.)

- A. 1 call per hour averaging 100 minutes.
- B. 2000 calls per hour averaging 3 minutes each.
- C. 3000 calls per hour averaging 2 minutes each.
- D. 3000 calls per hour averaging 3 minutes each.
- E. None of the above.

Answer: B, C

QUESTION 54:

With regard to echo, which of the following statements is false?

- A. The term "ERL" refers to a measurement of the volume of Echo heard by the user.
- B. Increasing the Echo-Cancellation coverage in an Echo Canceller may also increase Echo Canceller convergence time.
- C. Analog components in the voice path causes echo.
- D. Echo exists in a Circuit Switched environment, but usually goes unnoticed because of the flow delay.

Answer: A

Deploying Cisco Voice over IP Solutions; Davidson; Cisco Press p42

QUESTION 55:

You are a network administrator at Certkiller . You are troubleshooting an IOS Voice Gateway. Which command will produce detailed information about the codec, ERL, tx/rx packets, and dial peers on the current active calls?

- A. The show voice port command.
- B. The show voice call command.
- C. The show voice call active command.
- D. The show call active voice command.

Answer: D

http://www.cisco.com/univercd/cc/td/doc/product/software/ios123/123tcr/123tvr/vrht_sh1.htm#34981

QUESTION 56:

What is the traffic model typically used when dimensioning call center agents receive calls from infinite sources (PSTN callers) where call are queued during the busy hour?

- A. Erlang-B
- B. Erlang-C
- C. Binomial
- D. Extended Erlang-B
- E. Engset

Answer: B

Not A: This model, Erlang-B, block calls and do not queue.

QUESTION 57:

You are a network engineer at Certkiller . Certkiller has a voice gateway that is receiving calls from infinite sources (PSTN callers) during the busy hours when lost calls should be cleared (blocked).

What typical traffic model is required to dimension the number of gateway ports/trunks?

- A. Erlang-B
- B. Erlang B and Erlang C
- C. Erlang-C
- D. Poisson
- E. Binomial
- F. Engset
- G. Extended Erlang-B
- H. None of the above.

Answer: A

Explanation: A is the correct answer because the model with infinite sources and

with no call retries (lost calls cleared) is Erlang B. Extended Erlang B (answer G theoretically correct) is for systems with a percentage of call retries that should be taken into account.

QUESTION 58:

You are the technician at Certkiller . Your newly appointed Certkiller trainee wants to know what could cause a user to hear echoes of her own voice. What will your reply be? (Choose three.)

- A. Mismatch in impedance in the hybrid transformer.
- B. Gain in local loop.
- C. ERL is low at the trail circuit.
- D. A-3 db loss is taking place in local loop.

Answer: A, B, C

QUESTION 59:

What weighting are packets destined for the PQ given when PQ-WFQ is configured on an interface?

- A. 1024
- B. 56
- C. 12
- D. 0

Answer: D

<http://www.cisco.com/en/US/tech/ CK6 52/ CK6 98/topic1>

QUESTION 60:

You are a network administrator at Certkiller . The Certkiller network is shown in the following exhibit:

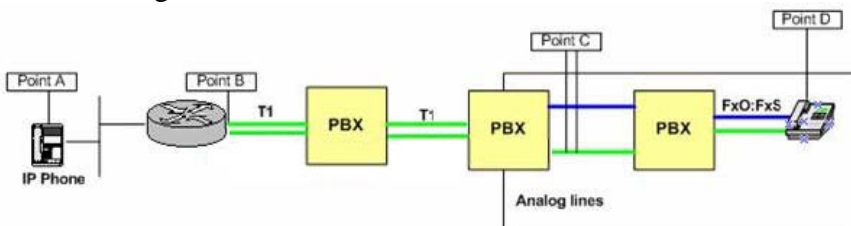

With reference to the exhibit, what section of the voice path represents the Tail Circuit?

- A. Between Point A and Point B.
- B. Between Point B and Point C.
- C. Between Point B and Point D.
- D. Between Point C and Point D.

Answer: C

Reference:

1. Cisco IP troubleshooting P416
- 2.

http://www.cisco.com/en/US/tech/CK652/CK698/technologies_tech_note09186a0080149a1f.shtml

QUESTION 61:

You are a network administrator at Certkiller . Your newly appointed Certkiller trainee

Wants to know what, according to Cisco's design guide, is the typical bandwidth needed for a single VoIP call (including layer 2) when using a g.729 codec, and no header compression.

What will your reply be?

- A. 64 Kbps
- B. 32 Kbps
- C. 16 Kbps
- D. 8 Kbps
- E. 4 Kbps

Answer: B

Actually for Ethernet it is 29.6kbps

QUESTION 62:

What is the range of UDP port numbers used in Cisco's VoIP implementation?

- A. 1699 to 3210
- B. 1100 to 2100
- C. 1225 to 2245
- D. 16384 to 32767
- E. 32769 to 64535

Answer: D

QUESTION 63:

You are a network administrator at Certkiller . Your newly appointed Certkiller trainee wants to know how a H.323 proxy Gatekeeper Request (GRQ) Registration, Admission, and Status (RAS) message is sent and by which endpoints. What will you tell your trainee? (Choose three.)

- A. Gateway.
- B. H.323 Terminal.
- C. Proxy.
- D. Gateway.
- E. Firewall.

Answer: A, B, C

QUESTION 64:

Certkiller has recently appointed a new trainee. The trainee wants to know what the target overall loss plan across a telephone network is. What will your reply be?

- A. 12dBm - 24dBm.
- B. 8dBm - 16dBm.
- C. 4dBm - 12dBm.
- D. 0dBm - 8dBm.

Answer: D

QUESTION 65:

You are a network administrator at Certkiller . Your newly appointed Certkiller trainee wants to know what a gatekeeper is. What will your reply be? (Choose two.)

- A. A compulsory component in a H.323 system which provides call control services to the H.323 endpoints.
- B. An optional component in a H.323 system which provides call control services to the H.323 endpoints.
- C. A compulsory component in a SIP system which provides call control services to the H.323 and SIP endpoints.
- D. Logically separate from the endpoints, but its physical implementation may coexist with a terminal, multipoint conference unit (MCU), gateway, multipoint controller (MP), or other non-H.323 LAN device.
- E. An optional component in a SIP system which provides call control services to the H.323 and SIP endpoints.

Answer: B, D

QUESTION 66:

You are a network administrator at Certkiller . Certkiller has a converged 512 Kbps MLP circuit. What set of commands will guarantee a maximum serialization delay of 15 ms on this circuit?

- A. ppp multilink fragment 960
- B. ppp multilink fragment 320
- C. ppp multilink fragment 640
ppp multilink interleave
- D. ppp multilink fragment-delay 15
ppp multilink interleave
- E. ppp multilink fragment-delay 15

Answer: D

To disable packet fragmentation, use the ppp multilink fragment disable command in interface configuration mode.

http://www.cisco.com/univercd/cc/td/doc/product/software/ios123/123cgcr/dial_r/dia_n1g.htm#1134762

QUESTION 67:

You are a network administrator at Certkiller . Certkiller has a H.323 network. Which of the following functions is NOT performed by the Gatekeeper on the Certkiller network?

- A. Call routing
- B. The Number to IP address translations
- C. Call authorization
- D. Call admission control
- E. Codec negotiation

Answer: E

QUESTION 68:

You are a network administrator at Certkiller . Your newly appointed Certkiller trainee wants to know what type of signalling provides Dialed Number Information Service (DNIS) on a T1/E1. What will your reply be?

- A. E&M
- B. Ground start
- C. Loop Start
- D. All of the above

Answer: D

TELEPHONY SIGNALING, Understanding How Digital T1 CAS (Robbed Bit Signaling) Works in IOS Gateways

http://www.cisco.com/en/US/tech/CK652/CK653/technologies_tech_note09186a00800e2560.shtml

QUESTION 69:

What is a DPA (Digital PBX Adapter) used for?

- A. To allow a customer to network VoiceMail systems and PBX together.
- B. To enable Calling-Name between CallManager and Meridian Mail systems.
- C. To connect an Octel 200/300/250/350 to CallManager.
- D. To connect CallManagerr to PBX.
- E. None of the above.

Answer: C

CISCO DPA 7600 SERIES GATEWAYS

<http://www.cisco.com/en/US/products/hw/gatecont/ps821/index.html>

QUESTION 70:

Where can the Gatekeeper be when Gateways are registering with a Gatekeeper?

- A. In a different subnet.
- B. On a remote LAN.
- C. On the same subnet.
- D. On the same LAN.
- E. Any of the options above.

Answer: E

QUESTION 71:

You are a network administrator at Certkiller . You want to implement a standards-based protocol that will allow CallManager to seamlessly integrate with another vendor's traditional PBX system. What protocol should you implement? (Choose three.)

- A. MGCP
- B. QSIG
- C. PRI NI-2
- D. SRST
- E. OSPF

Answer: A, B, C

The standards based protocols to connect to other pbx's are mgcp, qsig and pri.

CM utilizes a VoiceGateWay with one of three protocols:

MGCP

SIP

H.323

http://www.cisco.com/en/US/partner/products/sw/voicesw/ps556/products_usage_guidelines09186a00803b2b0a.html

Not D: SRST = Survivable Remote Site Telephony and is not a protocol as it is more of a philosophy. The question does not have anything to do with SRST.

SRST

CiscoSRST provides CiscoCallManager with fallback support for Cisco IP phones if a WAN failure is detected. Cisco SRST runs under the Cisco IOS stack and uses the Skinny protocol (SCCP) to interact with Cisco IP phones.

http://www.cisco.com/en/US/partner/products/sw/voicesw/ps556/prod_troubleshooting_guide_chapter09186a00

QUESTION 72:

You are a telephony trainee at Certkiller . The network administrator asks you what the advantage of Survivable Remote Site Telephony (SRST) design method is.

What will your reply be?

- A. It enhances the availability of CM distributed call processing.
- B. It enhances the availability of CM single site campus design.
- C. It enhances the availability of CM tool bypass.
- D. It enhances the availability of CM centralized call processing.
- E. It restricts calls to numbers such as 1-900 and International long distance calls

Answer: D

QUESTION 73:

What types of call processing functions do SRST preserve in a remote office in a CM network? (Choose two.)

- A. IP Phone to VoiceMail transcoding services.
- B. IP Phone to conference DSP resources.

- C. IP Phone to GW calls.
- D. IP Phone to IP Phone calls.
- E. CTI applications such as IP SoftPhones.

Answer: C, D, E

Explanation:

C, D: SRST preserve IP-to-IP calls (local calls), IP-to-PSTN calls and global Voicemail calls.

E: CME/SRST 4.0 added support for CTI applications like Softphone.

QUESTION 74:

You are the network administrator at Certkiller . Certkiller uses HSRP in conjunction with SRST to preserve the telephony functionality in a branch office as shown in the following exhibit:

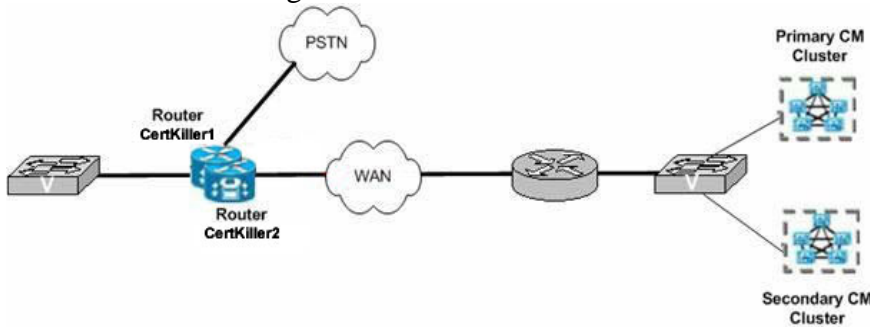

Should a WAN failure occur while the primary router, Router Certkiller 1 is in use, Router Certkiller 1 should switch to SRST mode to preserve telephony functions. However, if Router Certkiller 1 also fails, the HSRP backup router, Router Certkiller 2, must become the active router for the branch office and must take over SRST and routing functions for the branch office.

What types of physical connectivity must you duplicate on Routers Certkiller 1 and Certkiller 2 to ensure that Router Certkiller 2 will be effective in running SRST for the branch office? Select two.

- A. ISDN
- B. PSTN
- C. WAN
- D. CMs
- E. VLANs
- F. LAN

Answer: B, F

QUESTION 75:

You are the network administrator at Certkiller . The Certkiller Voice network is shown in

the following exhibit:

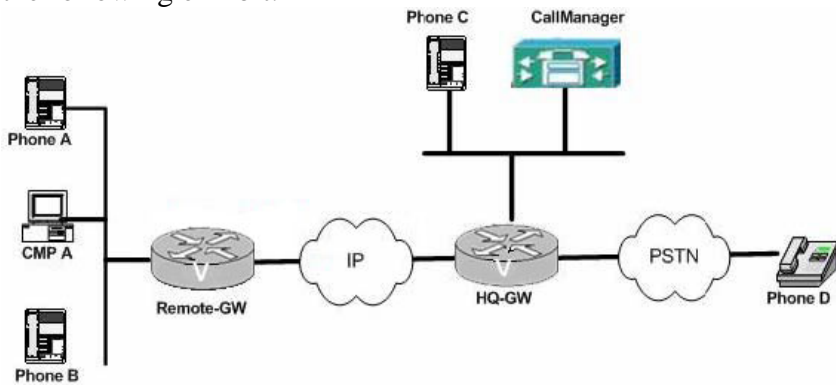

A Certkiller user at Phone A complains about a persistent echo on calls to the PSTN. The ERL has been determined to be 15db. The configuration on the HQ-GW voice T1 is as follows:

```
voice-port 1/0:15  
echo-cancel coverage 8  
end
```

What should be done resolve this problem?

- A. Increase the echo tail coverage
- B. Decrease the NLP threshold
- C. Decrease the output gain
- D. Increase the input gain
- E. Increase the output gain

Answer: A

Cisco IOS Voice, Video, and Fax Commands, echo-cancel coverage

http://www.cisco.com/univercd/cc/td/doc/product/software/ios122/122newft/122tcr/122tvr/vrg_e1.htm#998290

QUESTION 76:

You are contracted as a network administrator for a small company, Certkiller Inc.

Your newly appointed Certkiller trainee wants to know

What combination will give him the best video quality using a 128kbs video conference call?

What will your reply be?

- A. H.263 video and G.728 audio
- B. H.261 video and G.728 audio
- C. H.263 video and G.711 audio
- D. H.261 video and G.711 audio
- E. H.263 video and G.722 audio

Answer: A

QUESTION 77:

You are the network administrator at Certkiller . The Certkiller Voice network is shown in the following exhibit:

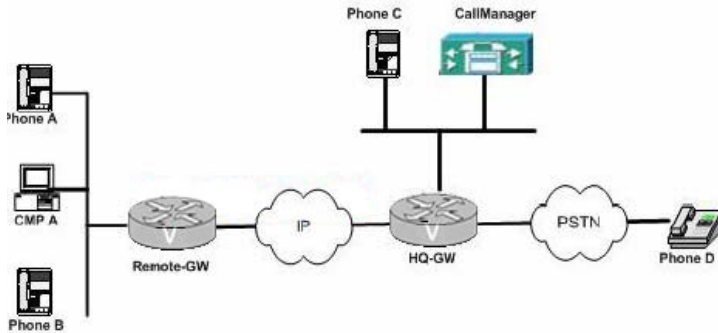

Everything in the Certkiller Voice network is under your control except for the PSTN.

The Certkiller user at IP Phone A complains of a persistent echo during all calls from IP Phone A to Analog Phone D.

What would be the best way to resolve this echo issue?

- A. Adjust the Echo Cancellation parameters on Phone D.
- B. Adjust the Echo Cancellation parameters on HQ-GW.
- C. Adjust the Echo Cancellation parameters on Phone A.
- D. Adjust the Echo Cancellation parameters on Remote-GW.
- E. Adjust the Echo Cancellation parameters on CallManager.

Answer: B

QUESTION 78:

On which criteria does a Cisco SIP Proxy Server use to make routing decisions?

- A. From: header
- B. To: header
- C. SDP parameters
- D. User-Portion on the Request -URI

Answer: D

QUESTION 79:

Which of the following tasks can the Cisco SIP Proxy not perform?

- A. Registrar Server.

- B. Redirect Server.
- C. Proxy Server.
- D. User Agent.

Answer: D

QUESTION 80:

Regardless of next-hop SIP device, what is the order in which CSPS will determine how to route the packet when you process a SIP message?

- A. Static Routes, GKTMP, Registry, LRQ to H.323 Gatekeeper
- B. Domain Routes, GKTMP, Registry, LRQ to H.323 Gatekeeper
- C. Static Routes, GKTMP, LRQ to H.323 Gatekeeper, Registry
- D. Registry, GKTMP, Static Route, LRQ to H.323 Gatekeeper

Answer: D

Cisco SIP Proxy Server Administration Guide p1-8

QUESTION 81:

You are a network administrator at Certkiller . Your newly appointed Certkiller trainee wants to know what SIP header a SIP Proxy is allowed to change. What will your reply be?

- A. The To header.
- B. The Request-URI.
- C. The Contact header.
- D. The From header.

Answer: B

CISCO SIP PROXY SERVER, F Call-Flow Scenarios

http://www.cisco.com/en/US/products/sw/voicesw/ps2157/products_administration_guide_chapter09186a0

QUESTION 82:

You are a network administrator at Certkiller . Your newly appointed Certkiller trainee wants to know what the following SMDI packet represents:

MD0010013D 0002215

What will your reply be?

- A. MWI OFF commands for extension 2215
- B. A "Call Forward No Answer" extension 2215 from extension 10013

- C. MWI ON command for extension 2215
- D. A "Forward All Calls", extension 10013 calling 2215
- E. Extension 2215 calling into voicemail on port 13

Answer: E

Troubleshooting Legacy Voice Mail Integration with Cisco CallManager 3.0 and 3.1

http://www.cisco.com/en/US/products/sw/voicesw/ps556/products_tech_note09186a00800a8956.shtml

QUESTION 83:

You are a network administrator at Certkiller . An IP Phone named Phone A is configured with the extension 1500. Another IP Phone named Phone B is configured with the extension 1501. What is the minimum configuration that will allow the two IP Phones to contact each other?

- A. Both phones must be on the same trunk.
- B. Both phones must be assigned the same Calling Search Space.
- C. Both phones extensions must be in the same partition.
- D. None of the above.

Answer: C

QUESTION 84:

When the CallManager goes down, what will the PBX do?

- A. Normal telephony will work
- B. There will nothing work
- C. There are only some problems with signaling, but calls will be forwarded
- D. ?

Answer: A

There is actually not enough information provided to give an answer but of the answers available the best choice would be that the PBX would continue to process normal telephone calls that it has control over (normal telephony would work). Calls between the two systems would not work nor would signaling.

QUESTION 85:

When is it possible for two Unity Servers to be placed in the same Dialing Domain?
(Select two.)

- A. When they are attached to the same PBX.

- B. When they are both assigned the same location ID.
- C. When they do not have to dial trunk access codes to reach each other's subscribers.
- D. When their subscribers do not have overlapping extensions.
- E. When they are in the same Exchange Site/Routing Group.

Answer: A, D

CISCO UNITY, Network Settings

http://www.cisco.com/en/US/products/sw/voicesw/ps2237/products_administration_guide_chapter09186a0

QUESTION 86:

You are a network administrator at Certkiller . Certkiller has a router that is connected to a PBX via a 4 wire E&M circuit. All the calls to the trunk are failing.

You suspect that the PBX is not receiving the incoming calls on the trunk.

To determine if this is the case, you want PBX to generate a dial tone when it receives an incoming call.

Which of the following will cause the PBX to generate dial tone?

- A. Short the E pin to the Tip pin.
- B. Short the E pin to the ground.
- C. Short the M pin to the ground.
- D. Short the M pin to the Ring pin.
- E. Short the Tip pin to the Ring pin.

Answer: B

Cisco Voice over Frame Relay, ATM & IP; Mc Querry; Cisco Press p43

QUESTION 87:

You are the network administrator at Certkiller . Certkiller has a Cisco IPCC deployment environment. CallManager is the routing client.

In the Certkiller network, perform what function will the ICM upon the receiving a call? (Choose two.)

- A. ICM plays pre-recorded announcements for callers waiting in queue if no agents are available.
- B. ICM plays music for callers waiting in queue if no agents are available.
- C. ICM Identifies and selects an available agent and determines the label to be returned to the routing client.
- D. ICM maps the Dialed Number to a call type and then maps the call type to a routing script.
- E. None of the above.

Answer: C, D.

QUESTION 88:

What happens when configuration changes are made to the CCMAAdmin page of a Subscriber CallManager?

- A. The configuration changes are made locally in the SQL Database, and replicated in the publisher SQL Database.
- B. The configuration changes are made in the publisher SQL Database, and replication to subscribers.
- C. The configuration changes are made locally in the SQL Database, and replicated up to the publisher immediately.
- D. The configuration changes are made locally in the SQL Database, and replicated up to the publisher at the next scheduled replication.

Answer: B

QUESTION 89:

You are a network administrator at Certkiller . The new Certkiller trainee wants to know what Inter-Cluster communications signalling includes in a CallManager cluster.

What will your reply be? (Select two.)

- A. Locations bandwidth and Shared media resources.
- B. Call detail records (CDR) database replication.
- C. Registration of devices
- D. Locations bandwidth Shared media resources.
- E. Device configuration replication.
- F. None of the above.

Answer: A, C

CIPT Course v3.3 p1-37

QUESTION 90:

What does CallManager use the concept of Location for?

- A. To define groups of devices based on physical location, in order to assign Primary and Backup CallManager servers.
- B. To group devices based on physical location, in order to delegate Administrative Control.
- C. To define the CODEDC to be used between two devices separated by a WAN link.

D. To define the bandwidth that can be used between two devices.

Answer: D

CIPT Course v3.3 p3-98

QUESTION 91:

You are a network administrator at Certkiller . Your newly appointed Certkiller trainee wants to know what the difference is between a route-group and a route-list. What will your reply be?

- A. Route-lists contain gateways for route-groups.
- B. Route-group contains a list of route-patterns.
- C. Route-lists contain a list of gateways.
- D. Route-groups contain route-lists which points to the gateways.
- E. Route-lists contain route-groups which point to the gateways.

Answer: E

CIPT Course v3.3 p3-22

QUESTION 92:

You are a network administrator at Certkiller . Your newly appointed Certkiller trainee wants to know why PRI is the preferred method for inter-connecting CallManager3.2 and below to PBX's. What will your reply be? (Select two.)

- A. It allows a customer to share their exiting Meridian Mail system with CallManager subscribers whilst delivering full functionality.
- B. It provides Caller ID functionality.
- C. It is the most cost effective solution available.
- D. It offers the highest level of inter-operability between CallManager and PBX's.
- E. It allows a customer to share their exiting VoiceMail system with CallManager.

Answer: C, D

QUESTION 93:

You are a network administrator at Certkiller . The Certkiller Voice network is configured as follows:

- * Phone A's device calling search space is CSS_Dev_A.
- * Phone A's Line 1 is assigned calling search space CSS_Line_A
- * Route Pattern 2XXX is placed in Partition Part_1.

* Route Pattern 20XX is placed in Partition Part_2.

* Route Pattern 200X is placed in Partition Part_3.

* CSS_Dev_A contains partition(s) Part_1.

* CSS_Line_A contains partition(s) Part_2.

If a call is made to 2001 from Phone A, using Line1, what route pattern will be used by Call Manager?

A. 200X in partition Part_3.

B. 20XX in partition Part_2.

C. 2XXX in partition Part_1.

D. None of the above.

Answer: B

QUESTION 94:

Your newly appointed Certkiller trainee wants to know by you what CallManager uses a Calling Search Space for.

What will your reply be?

A. To restrict calls to a particular range of numbers.

B. To enable the use of E911 services.

C. To enable the use of an overlapping dial plan.

D. To provide access-list-like security.

E. All of the above.

Answer: E

CIPT Solution Reference Network Design Chapter 7

QUESTION 95:

You are a network administrator at Certkiller . Your newly appointed Certkiller trainee wants to know how many different types of devices can register with a Cisco CallManager.

What will your reply be?

A. The number of calls a device handles in the busy hour.

B. All of the above.

C. The total number of each device type.

D. Memory and CPU resources each device type requires from the server.

E. Pagefile and CPU usage.

Answer: D

CIPT Solution Reference Network Design 6-3

QUESTION 96:

Exhibit:

phone -> gw -> fr -> atm -> gw -> phone

ATM to FR and Back over WAN for Voice-Transfer (FR <-> ATM). (Select two.)

- A.) FRF.8
- B.) FRF.11
- C.) FRF.12
- D.) FRF.15
- E.) FRF.16

Answer: A, B

QUESTION 97:

Transfer types from AMIS to Email-server.

- A.) Email-Message
- B.) Email-Message and Voice-Mail-Message
- C.) Voice-Mail-Message

Answer: C

QUESTION 98:

AMIS is used to:

- A. Send Email messages
- B. Send VoiceMail messages
- C. Send VoiceMail & Email messages
- D. Send Recorded names

Answer: B

QUESTION 99:

You are a network engineer for Certkiller , Inc. Your newly appointed Certkiller trainee asked you about the perspective of the CallManager. In particular, she wants to know which device the Unity TSP looks and behaves mostly like. What will your reply be?

- A. A TAPI Device

- B. A MGCP Gateway
- C. A Cisco IP Phone
- D. A H.323 Gateway
- E. A CTI Port

Answer: A

QUESTION 100:

You are a network administrator at Certkiller . You want to troubleshoot a FailSafe problem in Unity. Where should you look for detailed error messages?

- A. In the Application.Log.
- B. On the Status Monitor.
- C. In the Tempu.log.
- D. In the SDL Trace.
- E. In the System.log.

Answer: A

QUESTION 101:

Test Technologies and Bill, Inc recently merged to form Certkiller , Inc. You are appointed as the network administrator for Certkiller , Inc. An IP Phone from Test Technologies, named Phone A has been assigned to Calling Search Space A. Calling Search Space A contains the following partitions in the order shown, listed with their respective Routing Patterns:

Partition_A1, containing Route Pattern 1XXX

Partition_A2, containing Route Pattern 10XX

Phone A dials "1001". Which of the following statements is true?

- A. None of the route pattern is an exact match. Therefore, none will match and the caller will hear the re-order tone.
- B. Both patterns are equivalent matches. Therefore Call Manager will choose them the round robin fashion.
- C. Route Pattern 1XXX and 10XX both match, but since 1XXX is listed at the top it will be chosen first.
- D. Route Pattern 1XXX and 10XX both match, but since the 10XX is a better match it will be chosen.

Answer: D

http://www.cisco.com/en/US/products/sw/voicesw/ps556/products_administration_guide_chapter09186a00

QUESTION 102:

You are the network administrator at Certkiller . The Certkiller network is shown in the following exhibit:

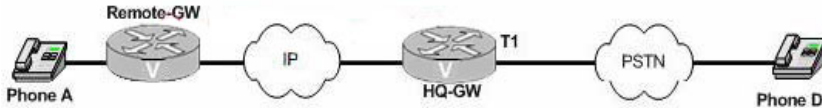

A Certkiller user located at phone A dials 5551212555. The GWs the Certkiller network are configured as follows:

REMOTE-GW

```
voice translation-profile CERTKILLER_1
translate called 1
voice translation-rule 1
rule 1 /\(555\)+\(.+\)//444\2/ type any national any isdn
dial-peer voice 1 voip
translation-profile outgoing CERTKILLER_1
session target ipv4.x.x.x.x
Port 0/0
```

HQ-GW

```
Interface FastEthernet0
Ip Address x.x.x.x y.y.y.y
voice translation-profile CERTKILLER_2
translate called 1
voice translation-rule 1
rule 1 /\(12\)+\(.+\)//911\2/type national unknown plan unknown isdn
dial-peer voice 1 pots
translation-profile outgoing CERTKILLER_2
Port 1/0:23
```

The call routing is working properly through the IP Network.
What digit string will be sent to the PSTN for termination?

- A. 5551212555
- B. 4441212555
- C. 555911911444
- D. 5551444555
- E. 5554442555

Answer: A

QUESTION 103:

You are a telephony trainee at Certkiller Inc. Your instructor asks you what industry-standard protocol the CallManager uses for integration to VoiceMail systems.

What will your reply be?

- A. T1-CAS
- B. H.323
- C. SMDI
- D. Q.931
- E. H.225.

Answer: C

QUESTION 104:

Which of the following Cisco Products can produce SMDI packets? (Choose three.)

- A. A Cisco Unity.
- B. A Cisco CallManager.
- C. A Cisco VG200 Voice Gateway.
- D. A Cisco VG248 Analog Phone Gateway.
- E. All of the above.

Answer: A, B, D

QUESTION 105:

You are a network engineer at Certkiller , Inc. Your newly appointed Certkiller trainee wants to know what SMDI message from CallManager CMI or VG248 allows a Voicemail system to provide a "Hearth-beat" function on a RS-232 serial link.

What will your reply be?

- A. MWI INV
- B. MWI BLK
- C. OP:MWI
- D. None of the above

Answer: C

Configuring CallManager 3.x for Integration to Voice Mail Systems via SMDI

http://www.cisco.com/en/US/products/sw/voicesw/ps556/products_configuration_example09186a0080160b

QUESTION 106:

What factor determines the fragmentation size on a T1/E1 Frame Relay circuit?

- A. Line speed.

- B. Burst Count.
- C. The Average CIR.
- D. The minimum CIR.
- E. The maximum CIR.

Answer: A

Explanation: The correct answer is 'Line Speed' because in cisco's documentation you can see a table regarding Line speed-Frame Relay fragment relationship to achieve about 10ms of serialization delay.

QUESTION 107:

You are a network administrator at Certkiller . You have been instructed to select the correct SMDI packet from the options below:
Select the correct SMDI packet:

- A. MVI010001N0002222 000112324
- B. MD0010001A0002222 000112324
- C. MC0010001D0002222 00012324
- D. ND0010001A0002222 00012324
- E. RD0010001B000222 00012324

Answer: B

CISCO CALLMANAGER, Troubleshooting Legacy Voice Mail Integration with Cisco CallManager 3.0 and 3.1

http://www.cisco.com/en/US/products/sw/voicesw/ps556/products_tech_note09186a00800a8956.shtml

QUESTION 108:

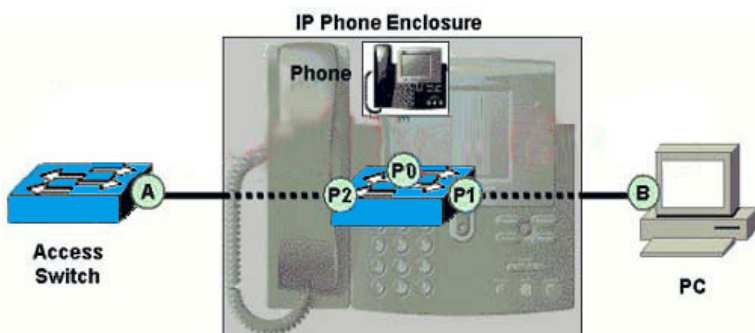

If a 7960 IP phone sends voice media frames towards the access switch, how will these frames be observed at point A

NOTE: Assume that a frame sniffer capturing data between the phone and the access switch

Assume that the access switch, a Cisco Catalyst 3524Xli is configured as:

```
interface FastEthernet0/1
power inline auto
speed auto
switchport trunk encapsulation dot1q
switchport trunk native vlan 12
switchport mode trunk
switchport voice vlan 112
switchport priority extend cos 0
spanning-tree portfast
```

NOTE: Assume the phone is connected into port FastEthernet0/1.

- A. The frame will be tagged with 802.1Q VLAN ID of 12, and will have an 802.1p cos value of 3.
- B. The frame will be tagged with 802.1Q VLAN ID of 112, and will have an 802.1p cos value of 5.
- C. The frame will be tagged with 802.1Q VLAN ID of 0, and will have an 802.1p cos value of 3.
- D. The frame will be un-tagged.

Answer: B

Explanation:

802.1Q is the IEEE standard for tagging frames on a trunk and supports up to 4096 VLANs. In 802.1Q, the trunking device inserts a 4-byte tag into the original frame and recomputes the frame check sequence (FCS) before the device sends the frame over the trunk link. At the receiving end, the tag is removed and the frame is forwarded to the assigned VLAN. 802.1Q does not tag frames on the native VLAN. It tags all other frames that are transmitted and received on the trunk. When you configure an 802.1Q trunk, you must make sure that you configure the same native VLAN on both sides of the trunk. IEEE 802.1Q defines a single instance of spanning tree that runs on the native VLAN for all the VLANs in the network. This is called Mono Spanning Tree (MST). This lacks the flexibility and load balancing capability of PVST that is available with ISL. However, PVST+ offers the capability to retain multiple spanning tree topologies with 802.1Q trunking.

The voice VLAN feature enables access ports to carry IP voice traffic from an IP phone. When the switch is connected to a Cisco 7960 IP Phone, the IP Phone sends voice traffic with Layer 3 IP precedence and Layer 2 class of service (CoS) values, which are both set to 5 by default. Because the sound quality of an IP phone call can deteriorate if the data is unevenly sent, the switch supports quality of service (QoS) based on IEEE 802.1P CoS. QoS uses classification and scheduling to send network traffic from the switch in a predictable manner

QUESTION 109:

What percentage of a standard G.729a packet is taken by IP, UDP and RTP headers? (NOTE: cRTP not used)

- A. 66%
- B. 50%
- C. 40%
- D. 33%
- E. 20%

Answer: A

Explanation:

Bandwidth and Bandwidth Efficiency -- For practical reasons, only G.729A and G.723.1 were considered in the tests. Both G.729A and G.723.1 are frame-based codecs. For each codec, the VoIP gateway supports several packetizing options, each using a different number of frames per packet. Since more frames per packet means longer delay, especially for G.729A (codec delay is 10 ms/frame) and G.723.1 (codec delay is 30 ms/frame), only 1-frame/packet and 2-frames.

The following important aspects of bandwidth utilization in VoIP:

Without silence suppression, the bandwidth per 5.3 kb/s (G.723.1) channel is 10.7 kb/s due to the 50 percent overhead.

Without silence suppression, the bandwidth per 8 kb/s (G.729) channel is 24 kb/s due to the 66.7 percent overhead.

To save bandwidth using silence suppression, the silence threshold in the VoIP gateway must be adjusted according to the ambient noise.

Under the same test conditions (the same voice files being transmitted), the bandwidth gain by silence suppression was 1.88 with a G.723.1 codec compared to 1.05 with a G.729 codec. This result was confirmed by repeating the same tests three times, and may indicate a G.729 silence suppression implementation problem in the VoIP gateway product used.

QUESTION 110:

What IOS feature can synthesize VoIP packets and measure latency, jitter and loss statistics?

- A. RTP Probe
- B. Extended Ping - VoIP Feature
- C. Real-Time Voice Responder
- D. Class-Based QoS MIB
- E. Service Assurance Agent

Answer: E

Explanation:

The Service Assurance Agent (SAA) is an both an enhancement to and a new name for the Response Time Reporter (RTR) feature that was introduced in Cisco IOS release 11.2. The feature allows you to monitor network performance by measuring key Service

Level Agreement (SLA) metrics such as response time, network resources, availability, jitter, connect time, packet loss and application performance.

QUESTION 111:

Study the exhibit carefully.

Consider the Low Latency Queuing (LLQ) configuration segment shown. How will the traffic in the two priority classes be handled by the LLQ algorithm?

```
policy-map WAN-EDGE
class VOICE1
  priority 100
class VOICE2
  priority 50
class VOICE CONTROL
  bandwidth 20
class class-default
  fair-queue
```

- A. There are two priority queues and traffic from each class will be funneled to its own queue.
- B. There is a single priority queue of 100K as that is the first statement encountered.
- C. This is an invalid LLQ configuration segment - you can only define one priority class.
- D. There is a single priority queue of 150K and traffic from both classes are treated FIFO within that queue.
- E. There is a single priority queue of 150K and traffic from both classes are treated WFQ within that queue.

Answer: D

Explanation:

LLQ provides strict PQ on ATM VCs and serial interfaces. This feature allows you to configure the priority status for a class within CBWFQ, and it is not limited to UDP port numbers, as is IP RTP Priority. LLQ and IP RTP Priority can be configured at the same time, but IP RTP Priority takes precedence.

FIFO provides basic store-and-forward capability. FIFO is the default queuing algorithm in some instances, thus requiring no configuration.

QUESTION 112:

What command will guarantee a maximum serialization delay on 10 ms on a converged 256 kbps Frame-Relay circuit?

- A. frame-relay fragment-delay 10
- B. frame-relay fragment 320
- C. frame-relay serialization-delay 10

- D. frame-relay fragment 640
- E. frame-relay fragment 160

Answer: B

Explanation:

This question requires that fragmentation is used over the Frame Relay and ISDN networks that will transport voice traffic. You should remember that voice is still required should the Frame Relay network fail. By fragmenting the data, you can tailor the packet interval and ensure that voice quality is not compromised over low bandwidth links. Some basic math is required to calculate the current real-time packet interval over the Frame Relay and ISDN network to begin as detailed in Table 1-3. Note the Frame Relay speed is 256 kbps and the ISDN is 64 kbps using only one B channel.

MTU Values According to Bandwidth

	Frame Relay (256 kbps)	ISDN (64 kbps)
No. Bytes TX'd per second	32,000	8,000
No. of bytes TX'd in 10ms	320	80

Above table shows, 32,000 are bytes transmitted every second over the Frame Relay circuit (256,000 divided by 8) if the real-time delay or serialization delay is to be 10 ms; 320 bytes can be transmitted in this period (32,000 * 10 ms). Similarly, 80 bytes can be transmitted for the ISDN with the circuit speed of 64 kbps.

QUESTION 113:

Class of Service (CoS) is a:

- A. Method of classifying different time periods which have the greatest call volume; assist telephone companies with designing their network to a certain capacity
- B. Portion of the IP header that relates to the service level of the packet
- C. General term that describes a level of service necessary for a specific application
- D. Method of classifying different traffic flows into a category and applying a particular quality of service (QoS) for that flow

Answer: D

Explanation:

Without a means of setting data delivery policies, all data within a network infrastructure receives equal treatment. A download of an inconsequential but large graphics file would get the same priority as an on-line transaction processing an update of a critical customer order. Even in the absence of mixed traffic in a shared network, some applications require more strict enforcement of data delivery. In Fibre Channel SANs, for example, the vast majority of applications are run over fabrics using connectionless class 3 service.

Class 3 provides best-effort delivery and no acknowledgment of data receipt. The next higher level of service is class 2, which provides acknowledgment, and above class 2 there is class 1, which provides both connection establishment and frame acknowledgment. The tradeoff for improved class of service is normally performance. Acknowledgment requires additional processing on both ends to monitor frame transmission and receipt.

In the hierarchy of data delivery, class of service is a subset of QoS, although the two terms are sometimes used interchangeably when referring to specific implementations. Class of service typically refers to prioritization of different types of data during transport, whereas QoS may also include higher levels of service such as guaranteed bandwidth and expedited delivery of data. In IP networks, a variety of methods are available for providing different classes and qualities of service. When scaling from low to high service levels, additional requirements placed on network equipment result in greater complexity and cost. As with any advanced service, the customer must determine whether their data deserves the very best or whether it can be reasonably accommodated with the default features provided by the vendor.

QUESTION 114:

Exhibit:

```
interface ATM4/0.60 point-to-point
  description ATM Link to BRANCH#60
  bandwidth 3000
  ip address 10.108.90.1 255.255.255.252
  pvc BRANCH#6000/60
  vbr-nrt 3000 3000
  tx-ring-limit ___
  service-policy output WAN-EDGE
```

The low-speed ATM PVC shown carries both voice and data traffic. What is the most appropriate value for the tx-ring?

- A. 0
- B. 3
- C. 10
- D. 15
- E. 60

Answer: B

Explanation:

The transmission (tx) ring is the first-in, first-out (FIFO) buffer used to hold frames before transmission at the DSL driver level. The tx ring defines the maximum number of packets that can wait for transmission at Layer 2. The tx ring complements the ability of LLQ to minimize jitter and latency of voice packets. For maximum voice quality, use a low tx ring setting. For maximum data throughput, use a high tx ring setting. You can configure the size of the tx ring for each permanent virtual circuit (PVC). The default value is 60. However, the value of the setting can be 2 through 60 on Cisco1700,

Cisco2600, and Cisco3600 series routers. A low tx ring setting, such as 2 or 3, is required for latency-critical traffic. For example, when the tx ring limit is configured as 3 and LLQ is configured on the PVC, the worst case delay for a voice packet is the time required to transmit three data packets. When the buffering is reduced by configuring the tx ring limit, the delay for voice packets is reduced by a combination of the tx ring and LLQ mechanism.

QUESTION 115:

One of the most important aspects of design criteria is minimizing total one-way end-to-end delay. This total delay has been found to be acceptable as long as it remains within:

- A. 0 to 1 second
- B. 0 to 150 milliseconds
- C. 0 to 500 milliseconds
- D. 0 to 300 milliseconds

Answer: B

QUESTION 116:

When PQ-WFQ is configured on an interface, the packets destined for the PQ are given a weighting of:

- A. 0
- B. 128
- C. 4096
- D. 32767

Answer: A

Explanation:

PQ guarantees strict priority in that it ensures that one type of traffic will be sent, possibly at the expense of all others. For PQ, a low priority queue can be detrimentally affected, and, in the worst case, never allowed to send its packets if a limited amount of bandwidth is available or if the transmission rate of critical traffic is high.

Weighted fair queueing (WFQ). WFQ offers dynamic, fair queueing that divides bandwidth across queues of traffic based on weights. (WFQ ensures that all traffic is treated fairly, given its weight.) To understand how WFQ works, consider the queue for a series of File Transfer Protocol (FTP) packets as a queue for the collective and the queue for discrete interactive traffic packets as a queue for the individual. Given the weight of the queues, WFQ ensures that for all FTP packets sent as a collective an equal number of individual interactive traffic packets are sent.)

QUESTION 117:

Which are the three elements to MQC?

- A. CallManager, IP Phones and SRST
- B. Gatekeeper, H.323 Proxy and RSVP
- C. Mean Opinion Score, representative sampling, Standard Deviation
- D. Class-map, Policy-map and Service-policy statement
- E. DSP, Codec and Sampling Rate

Answer: D

Explanation:

The MQC is a command-line interface (CLI) structure that allows you to create traffic policies and attach these policies to interfaces.

In the MQC, the class-map command is used to define a traffic class (which is then associated with a traffic policy). The purpose of a traffic class is to classify traffic.

The Modular quality of service (QoS) CLI structure consists of the following three processes:

Defining a traffic class with the class-map command.

Creating a traffic policy by associating the traffic class with one or more QoS features (using the policy-map command).

Attaching the traffic policy to the interface with the service-policy command.

A traffic class contains three major elements: a name, a series of match commands, and, if more than one match command exists in the traffic class, an instruction on how to evaluate these match commands. The traffic class is named in the class-map command line; that is, if you enter the class-map cisco command while configuring the traffic class in the CLI, the traffic class would be named "cisco".

The match commands are used to specify various criteria for classifying packets. Packets are checked to determine whether they match the criteria specified in the match commands. If a packet matches the specified criteria, that packet is considered a member of the class and is forwarded according to the QoS specifications set in the traffic policy. Packets that fail to meet any of the matching criteria are classified as members of the default traffic class.

QUESTION 118:

The jitter buffer is used for:

- A. Concealing variable interframe gaps
- B. Re-ordering out of sequence voice packets
- C. Encoding analog voice into digital voice
- D. Multiplexing multiple voice calls

Answer: A

Explanation:

Jitter is defined as a variation in the delay of received packets. At the sending side, packets are sent in a continuous stream with the packets spaced evenly apart. Due to network congestion, improper queuing, or configuration errors, this steady stream can become lumpy, or the delay between each packet can vary instead of remaining constant. When a router receives a Real-Time Protocol (RTP) audio stream for Voice over IP (VoIP), it must compensate for the jitter that is encountered. The mechanism that handles this function is the playout delay buffer. The playout delay buffer must buffer these packets and then play them out in a steady stream to the digital signal processors (DSPs) to be converted back to an analog audio stream. The playout delay buffer is also sometimes referred to as the de-jitter buffer.

QUESTION 119:

Exhibit:

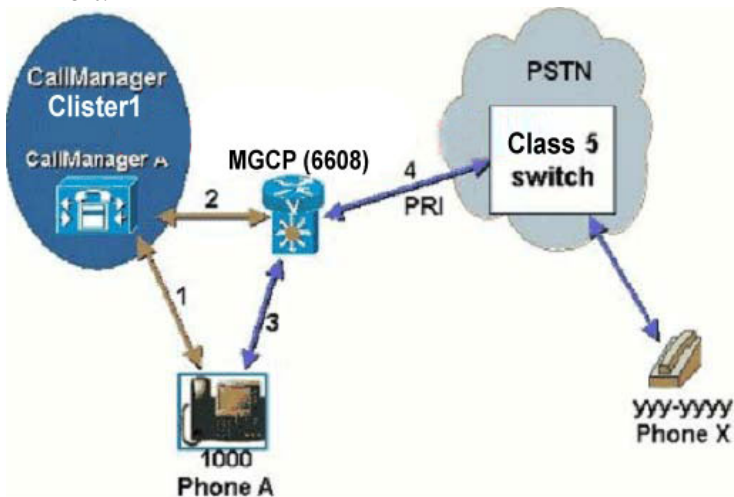

Assume that the gateway is a 6608 blade configured as a gateway and running MGCP; Call Manager runs version 3.1, and that a call is made from phone A to phone X. All IP streaming is G.711. Each of the logical links represented carries certain types of traffic. On which links can RTP traffic be seen?

- A. 2, 3, and 4
- B. 3 only
- C. 2 and 3
- D. 1, 2, 3, and 4
- E. 1 and 4

Answer: B

Explanation:

Enabling compression on both ends of a low-bandwidth serial link can greatly reduce the network overhead if it carries a substantial amount of Real-Time Protocol (RTP) traffic. Although the multicast backbone (MBONE)-style RTP traffic has higher payload sizes, compact encodings such as code excited linear prediction (CELP) can also help considerably.

QUESTION 120:

What paragraph best describes Pulse Code Modulation (PCM)?

A. PCM converts analog sound into digital form by sampling the analog sound 16000 times per second and converting each sample into a numeric code. The Nyquist theorem states that when sampling an analog signal at twice the rate of the highest frequency of interest, one can accurately reconstruct that signal back into its analog form. Since most speech content is below 4000 Hz (4 kHz), the sampling rate needed is 16000 times per second (225 microseconds between samples): The transmission rate is obtained by multiplying 8000 samples per second times 8 bits per sample, giving 64,000 bits per second.

B. PCM converts analog sound into digital form by sampling the analog sound 8000 times per second and converting each sample into a numeric code. The Nyquist theorem states that when sampling an analog signal at twice the rate of the highest frequency of interest, one can accurately reconstruct that signal back into its analog form. Since most speech content is below 4000 Hz (4 kHz), the sampling rate needed is 8000 times per second (125 microseconds between samples): The transmission rate is obtained by multiplying 8000 samples per second times 8 bits per sample, giving 64,000 bits per second.

C. PCM converts analog sound into digital form by sampling the analog sound 8000 times per second and converting each sample into a numeric code. The Bellman Ford theorem states that when sampling an analog signal at twice the rate of the highest frequency of interest, one can accurately reconstruct that signal back into its analog form. Since most speech content is below 4000 Hz (4 kHz), the sampling rate needed is 8000 times per second (125 microseconds between samples): The transmission rate is obtained by multiplying 8000 samples per second times 8 bits per sample, giving 64,000 bits per second.

D. All of the above are correct and it depends what type of CODEC is used.

Answer: B

Explanation: The Nyquist theorem is all about sample rate.

A scientist by the name of Harry Nyquist discovered that the original analog signal can be reconstructed if enough samples are taken. He determined that if the sampling frequency is at least twice the highest frequency of the original input analog voice signal, this signal can be reconstructed by a low-pass filter at the destination.

http://www.cisco.com/warp/public/788/signalling/waveform_coding.html

Not C: The Bellman Ford theorem has nothing to do with PCM. Bellman Ford theorem is for best path computation within a routing protocol.

QUESTION 121:

In VoIP, once TCP receives a request for opening a voice channel on port 1720, a new TCP port is allocated for (Note: assume no Fast Start):

- A. H.225 call setup negotiation
- B. H.245 capability exchange negotiation
- C. H.323 call setup negotiation
- D. UDP port negotiation
- E. G.726 call compression

Answer: B

Explanation:

The figure shows an H.323 basic call setup exchange between two gateways. The optional gatekeeper is not present in this example. Although gateways are shown, the same procedure is used when one or both endpoints are an H.323 terminal.

The flow procedure with a gatekeeper includes these steps:

1. The originating gateway initiates an H.225.0 session with the destination gateway on registered TCP port 1720. The gateway determines the IP address of the destination gateway internally; the gateway has the IP address of the destination endpoint in its configuration or it knows a DNS resolvable domain name for the destination.
2. Call setup procedures based on Q.931 create a call signaling channel between the endpoints.
3. The endpoints open another channel for the H.245 control function. The H.245 control function negotiates capabilities and exchanges logical channel descriptions.
4. The logical channel descriptions open Real-Time Transport Protocol (RTP) sessions.
5. The endpoints exchange multimedia over the RTP sessions.

QUESTION 122:

A method for touch-tone phones in which each digit corresponds to one of 16 combinations of pairs of sine waves chosen from eight different frequencies is called:

- A. In-band signaling
- B. Ear and Mouth or REceive and TransMit
- C. Multifrequency
- D. Out-of-Band signaling
- E. Dual tone multifrequency tone detection

Answer: E

QUESTION 123:

Study the exhibit carefully.

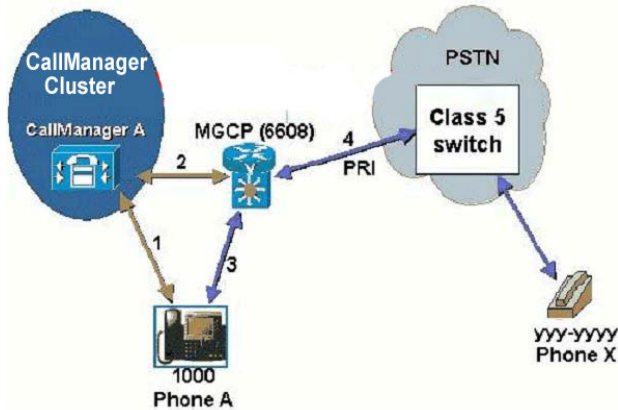

Assume that the gateway is a 6608 blade configured as a gateway and running MGCP; Call Manager runs version 3.1, and that a call is made from phone A to phone X. All IP streaming is G.711. Each of the logical links represented carries certain types of traffic. On which links can q.931 traffic be seen?

- A. 2 and 3
- B. 2, 3, and 4
- C. 1 and 4
- D. 1, 2, 3, and 4
- E. 2 and 4

Answer: E

QUESTION 124:

H .323 RAS (Registration, Authorization and Status) messages are sent using:

- A. TCP/IP
- B. UDP/IP
- C. ICMP
- D. RTMP

Answer: B

Explanation:

1. RAS Registration and Unregistration

Registration is the process by which gateways, terminals, and/or MCUs join a zone and

inform the gatekeeper of their IP and alias addresses. Registration occurs after the discovery process. Every gateway can register with only one active gatekeeper. There is only one active gatekeeper per zone.

2. RAS Admissions Admission messages between endpoints and gatekeepers provide the basis for call admissions and bandwidth control. Gatekeepers authorize access to H.323 networks with the confirmation of or rejection of an admission request.

3. RAS Status Information The gatekeeper can use the RAS channel in order to obtain status information from endpoints. You can use the RAS in order to monitor whether the endpoint is online or off-line. This table defines the RAS status information messages:
RAS Gatekeeper Discovery There are two processes by which H.323 terminals/gateways discover their zone gatekeepers:

* Unicast Discovery (manual method)-Uses UDP port 1718. In this process, endpoints are configured with the gatekeeper IP address and can attempt registration immediately. The gatekeeper replies with a gatekeeper confirm (GCF) or gatekeeper rejection (GRJ) message.

* Multicast Discovery (auto-discovery)
-Uses UDP multicast address 224.0.1.41. Auto discovery enables an endpoint to discover its gatekeeper through a multicast Gatekeeper Request (GRQ) message. Because endpoints do not have to be statically configured for gatekeepers, this method has less administrative overhead. A gatekeeper replies with a GCF or GRJ message. A gatekeeper can be configured to respond only to certain subnets.

QUESTION 125:

In general, fax relay is:

- A. More tolerant than voice to packet loss
- B. Less tolerant than voice to packet loss
- C. As tolerant as voice to packet loss
- D. Not subject to packet loss

Answer: B

Explanation:

Fax relay is the default mode for passing faxes through a VoIP network, and Cisco fax relay is the default fax relay type on Cisco voice gateways. This capability has been supported in CiscoIOS Release 11.3 and later releases and is widely available. Cisco fax relay uses Real-Time Transport Protocol (RTP) to transport the fax data.

Cisco fax relay is configured on the VoIP dial peers that direct calls into and out of the packet network. Cisco fax relay can be configured under the H.323 and Session Initiation Protocol (SIP) call control protocols.

Cisco fax relay supports fax relay packet loss concealment, which is a technique that allows gateways to disregard packet loss rates that might otherwise cause fax failures. High-end fax machines with the memory to store page data often are able to use Error Correction Mode (ECM) for error-free page transmission. When ECM is enabled, a fax

page is transmitted in a series of blocks that contain frames with packets of data. After receiving the data for a complete page, a receiving fax machine notifies the transmitting fax machine of any frames with errors. The transmitting fax machine then retransmits the specified frames. This process is repeated until all frames are received without errors. If the receiving fax machine is unable to receive an error-free page, the fax transmission may fail and one of the fax machines may disconnect. On networks that have a packet loss rate greater than 2 per cent, fax transmissions routinely fail when ECM is enabled because of ECM's low tolerance for packet loss.

QUESTION 126:

A commonly used instance of ADPCM, which encodes using 4-bit samples, giving a transmission rate of 32 kbps is called:

- A. ITU-T G.711
- B. ITU-T G.723.1
- C. ITU-T G.726
- D. ITU-T G.728
- E. ITU-T G.729

Answer: C

Explanation:

Another compression method often used is ADPCM. In ADPCM the bandwidth required to transmit a 64 kbps voice channel across a network is reduced by applying a formula to previous samples that adaptively predicts the range of values for the next sample. The transmitter then encodes the difference in level between the previous sample and the present sample, on a scale set by the prediction and passes this information to the receiver. Because the receiver has the same data to work with as the transmitter (the transmitted ADPCM samples), it is able to reconstruct the PCM data used by the transmitter.

Different ADPCM algorithms exist that differ primarily in the number of bits that make up one sample. The different algorithms are typically described by the total bit rate after the compression.

1. 32-kbps ADPCM uses 4-bit samples
2. 24-kbps ADPCM uses 3-bit samples
3. 16-kbps ADPCM uses 2-bit samples

A commonly used instance of ADPCM encoding, G.726 encodes using 4-bit samples, giving a transmission rate of 32 kbps. Unlike PCM, the four bits do not directly encode the amplitude of speech, but the differences in amplitude as well as the rate of change of that amplitude, by applying some rudimentary linear prediction.

G.726-Describes ADPCM coding at 40, 32, 24, and 16 kbps. ADPCM-encoded voice can be interchanged between packet voice, PSTN, and PBX networks, provided the PBX networks are configured to support ADPCM.

QUESTION 127:

What is considered a node in a H.323 network?

- A. Gateway
- B. Gatekeeper
- C. Proxy
- D. All of the above

Answer: D

Explanation:

H.323 is a standard for communication protocols from the International Telecommunications Union Telecommunication Standardization Sector (ITU-T); Version 4 is the current version. H.323 was created to provide multimedia communication across a packet network. The protocol can handle video and data, in addition to audio. H.323 interoperates well with the public switched telephone network (PSTN) in translating between call setup and control signals used in an IP network and those used in a switched-circuit network. H.323 is widely used in video conferencing deployments. Gateways that use H.323 do not depend on a call agent, as with Media Gateway Control Protocol (MGCP). H.323 is the default gateway protocol on Cisco routers. This chapter focuses on Cisco IOS H.323 gateways, although the concepts apply to all H.323 gateways.

Cisco Voice Gateways and Gatekeepers provides detailed solutions to real-world problems encountered when implementing a VoIP network. This practical guide helps you understand Cisco gateways and gatekeepers and configure them properly. Gateway selection, design issues, feature configuration, and security and high-availability issues are all covered in depth. The abundant examples, screen shots, configuration snips, and case studies make this a truly practical and useful guide for anyone interested in the proper implementation of gateways and gatekeepers in a VoIP network. Emphasis is placed on the accepted best practices and common issues encountered in real-world deployments.

Cisco Voice Gateways and Gatekeepers is divided into four parts. Part I provides an overview of an IP voice network. Part II is dedicated to voice gateways, including discussions of Media Gateway Control Protocol (MGCP); H.323; Session Initiation Protocol (SIP); voice circuit options; connecting to the PSTN, PBX, and IP WAN; dial plans; digit manipulation; route selection; class of restriction; Survivable Remote Site Telephony (SRST) and MGCP fallback; digital signal processor (DSP) resources; and Tool Command Language (Tcl) scripts and Voice XML (VXML). Part III addresses voice gatekeepers, including detailed deployment and configuration. Part IV is dedicated to IP-to-IP gateways.

QUESTION 128:

To provide for a standard approach for offering voice and fax over Frame Relay, the Frame Relay Forum released a standard, which describes frame formats, conformance requirements, and compression algorithms to support voice and fax over Frame Relay. The standard is:

- A. FRF.12
- B. FRF.11
- C. FRF.11 & FRF.12
- D. H.245

Answer: B

Explanation:

Cisco addresses the lack of end-to-end call parameter negotiation and call setup syntax in FRF.11 by implementing a proprietary Q.931-like session protocol running on a user-configurable CID of an FRF.11-format multiplexed DLCI. The Cisco-switched Voice over Frame Relay protocol handles call setup and parameter negotiation for both endpoints and intermediate nodes within the (multihop) call path. The call setup mechanism originally implemented in the Cisco MC3810 is used; this mechanism can be used for either permanent switched (Cisco-trunk) or dynamic switched calls. The Cisco-switched VoFR protocol includes forwarding of the called telephone number and supports tandem switching of the call over multiple Frame Relay PVC hops.

A tandem node is an intermediate router node within the Frame Relay call path. Its purpose is to switch the frames from one PVC subchannel to another (from one VoFR dial peer onto another VoFR dial peer) as the frames traverse the network. Use of tandem router nodes also avoids the need to have complete dial-plan information present on every router.

QUESTION 129:

Real-Time Transport Protocol (RTP) provides: (Choose three.)

- A. Payload header and content identification
- B. Sequence numbering
- C. Feedback to calling and called party about the quality of connection
- D. Simple time-stamp & reconstruction
- E. Lost packet statistics and round trip times

Answer: A, B, D

Explanation:

RTP is the Internet-standard protocol for the transport of real-time data, including audio and video. The compression algorithm defined in this document draws heavily upon the design of TCP/IP header compression as described in RFC 1144. It can be used for media on demand as well as interactive services such as Internet telephony. RTP consists of a

data part and a control part, called RTCP. The data part of RTP is a thin protocol that provides support for applications with real-time properties such as continuous media (for example, audio and video), including timing reconstruction, loss detection, and content identification. RTCP provides support for real-time conferencing of groups of any size within an Internet. This support includes source identification and support for gateways such as audio and video bridges as well as multicast-to-unicast translators. It offers QoS feedback from receivers to the multicast group, as well as support for the synchronization of different media streams.

QUESTION 130:

The IOS GWs support ECMA QSIG. CM, in MGCP call Agent mode, supports ISO QSIG. What implications does this have on an IP telephony network? Select two

- A. None, the ISO standard is a superset of the ECMA standard.
- B. None, as long as the IOS GW remains in contact with the CM at all times.
- C. During MGCP GW Fallback, no calls to the attached QSIG PBX will work.
- D. During MGCP GW Fallback, basic calls to the attached QSIG PBX will work.
- E. During MGCP GW Fallback, all call functionality to the attached QSIG PBX will work.

Answer: B, D

QUESTION 131:

What ITU-T logarithmic pulse code modulation (PCM) standard (G.711) used in the conversion between analog and digital signals is used mainly in Europe?

- A. MU-law
- B. A-law
- C. MU-law & A-law
- D. None of the above

Answer: B

Explanation:

Companding refers to the process of first compressing an analog signal at the source, and then expanding this signal back to its original size when it reaches its destination. The term companding is created by combining the two terms, compressing and expanding, into one word. At the time of the companding process, input analog signal samples are compressed into logarithmic segments. Each segment is then quantized and coded using uniform quantization. The compression process is logarithmic. The compression increases as the sample signals increase. In other words, the larger sample signals are compressed more than the smaller sample signals. This causes the quantization noise to

increase as the sample signal increases. A logarithmic increase in quantization noise throughout the dynamic range of an input sample signal keeps the SNR constant throughout this dynamic range. The ITU-T standards for companding are called A-law and u-law.

A-law and u-law Companding A-law and u-law are audio compression schemes (codecs) defined by Consultative Committee for International Telephony And Telegraphy (CCITT) G.711 which compress 16-bit linear PCM data down to eight bits of logarithmic data.

A-law Componder

Limiting the linear sample values to twelve magnitude bits, the A-law compression is defined by this equation, where A is the compression parameter (A=87.7 in Europe), and x is the normalized integer to be compressed.

$$F(x) = \begin{cases} \frac{A * |x|}{1 + \ln(A)} & 0 \leq |x| < \frac{1}{A} \\ \frac{\text{sgn}(x) * (1 + \ln(A|x|))}{1 + \ln(A)} & \frac{1}{A} \leq |x| \leq 1 \end{cases}$$

u-law Componder

Limiting the linear sample values to thirteen magnitude bits, the u-law (u-law and Mulaw are used interchangeably in this document) compression is defined by this equation, where m is the compression parameter (m =255 in the U.S. and Japan) and x is the normalized integer to be compressed.

$$F(x) = \frac{\text{sgn}(x) * \ln(1 + \mu|x|)}{\ln(1 + \mu)} \quad 0 \leq |x| \leq 1$$

A-law standard is primarily used by Europe and the rest of the world. u-law is used by North America and Japan.

QUESTION 132:

The terms "Wink start", "Delay start" and "Immediate start" are applicable to:

- A. Analog E&M Signaling
- B. T1 CAS E&M signaling
- C. E1 CAS E&M Signaling
- D. Analog DID Signaling
- E. All of the above

Answer: A

Explanation:

Analog trunk circuits connect automated systems, such as a private branch exchange

(PBX) and the network such as a central office (CO). The most common form of analog trunking is the E&M interface. E&M Signaling is commonly referred to as "ear & mouth" or "recEive and transMit", but its origin comes from the term earth and magnet. Earth represents electrical ground and magnet represents the electromagnet used to generate tone.

E&M signaling defines a trunk circuit side and a signaling unit side for each connection similar to the data circuit-terminating equipment (DCE) and data terminal equipment (DTE) reference type. Usually the PBX is the trunk circuit side and the Telco, CO, channel-bank, or Cisco voice enabled platform is the signaling unit side.

A. Immediate StartThe originating end seizes the line by going off hook and, without waiting for a response, it begins to output digits. The address signaling used with immediate-start signaling consists only of dial-pulsing.

B. Wink-StartThe originating end seizes the line by going off-hook. It waits for acknowledgement from the other end before outputting digits. This serves as an integrity check that will identify a malfunctioning trunk and allow the network to send a re-order tone to the calling party.

C. Delay DialThe originating end seizes the line and waits 200 ms to see if the far end is on-hook. If so, the originating end then outputs digits. If the far end is off-hook, the originating end waits until the far end is on-hook before outputting digits.

QUESTION 133:

What does SMDI stand for?

- A. Serial Message De-muxing Interface
- B. Simple Message Desk Interface
- C. Skinny Message De-muxing Interface
- D. Simple Modular Disk Interface
- E. None of the above

Answer: B

Explanation:

Simplified Message Desk Interface (SMDI) is a standard for integrating voice mail systems to PBXs or Centrex systems. Connecting to a voice mail system via SMDI and using either analog FXS or digital T1 PRI would require either SCCP or MGCP protocol because H.323 devices do not identify the specific line being used from a group of ports. Use of H.323 gateways for this purpose means the CiscoMessage Interface cannot correctly correlate the SMDI information with the actual port or channel being used for an incoming call.

QUESTION 134:

Which Cisco Products can provide SMDI packets? (Choose three.)

- A. Cisco VG200 Voice Gateway
- B. Cisco VG248 Analog Phone Gateway
- C. Cisco Call Manager
- D. Cisco Unity
- E. Cisco IAD-2400

Answer: B, C, D

Explanation:

Simplified Message Desk Interface (SMDI) is a standard for integrating voice mail systems to PBXs or Centrex systems. Connecting to a voice mail system via SMDI and using either analog FXS or digital T1 PRI would require either SCCP or MGCP protocol because H.323 devices do not identify the specific line being used from a group of ports. Use of H.323 gateways for this purpose means the CiscoMessage Interface cannot correctly correlate the SMDI information with the actual port or channel being used for an incoming call.

Cisco VG248 Analog Phone Gateway, Cisco Call Manager and Cisco Unity provides the SMDI packets.

QUESTION 135:

AAA Can be used for: (Choose three.)

- A. Unified messaging
- B. Admission
- C. Authentication
- D. Security
- E. Architecture
- F. Administration
- G. Billing

Answer: C, D, G

Explanation:

Authentication, authorization, and accounting (AAA) is a way to control who is allowed to access your network (authenticate), what they can do while they are there (authorize), and to audit what actions they performed while accessing the network (accounting).

AAA can be used in Internet Protocol Security (IPSec) to provide preshared keys during the Internet Security Association and Key Management Protocol (ISAKMP) process or to provide per-user authentication, known as XAUTH, during ISAKMP. AAA can be used to provide a mechanism for authorizing commands that administrators enter at the command line of a Cisco device. This is called command-line authorization. AAA is also seen in a Virtual Private Dial-Up Networking (VPDN) tunnel set up between two routers. It is overall a very simple process to configure. In fact, it is easily comparable to

day-to-day scenarios such as gaining access to golf clubs or sitting in first class on a commercial airline. In each of these situations, you must provide some type of proof as to your right to enter the golf club or sit in a nice comfortable first-class seat.

QUESTION 136:

When provisioning Cisco Call Manager device weights, what is taken into account?

- A. The total number of devices by type and BHCA per device
- B. The deployment model (Centralized or Distributed Call Processing)
- C. The server model and type
- D. A and C

Answer: D

QUESTION 137:

Private Line Auto Ringdown (PLAR) is a way to bypass dial tone from the:

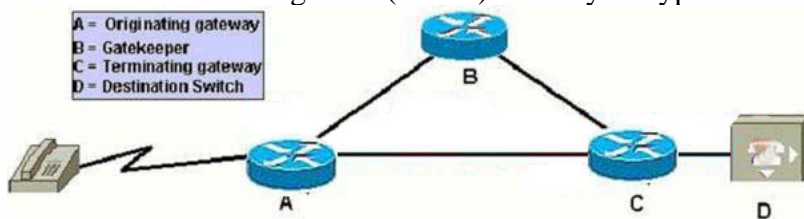

- A. Originating Gateway
- B. Gatekeeper
- C. Terminating Gateway
- D. Destination Switch

Answer: A

QUESTION 138:

When Direct Inward Dialing is used on a POTS dial peer and an incoming POTS call center enters the router: (Choose two.)

- A. The number that is dialing (ANI) automatically becomes the destination-pattern number for the IP destination.
- B. The number that is dialed (DNIS) automatically becomes the destination-pattern number for the IP destination.
- C. The number that is dialing (ANI) automatically becomes the destination-pattern number for the telephony destination.

- D. The number that is dialed (DNIS) automatically becomes the destination-pattern number for the telephony destination.
- E. The number that is dialed (DNIS) & the number that is dialing (ANI) automatically becomes the destination-pattern number for the IP & telephony destination.

Answer: B, D

QUESTION 139:

In a 128 kbs videoconference call, what combination will give you the best video quality?

- A. H.261 video and G.711 audio
- B. H.261 video and G.728 audio
- C. H.263 video and G.711 audio
- D. H.263 video and G.728 audio
- E. H.263 video and G.722 audio

Answer: D

QUESTION 140:

AMIS is used to:

- A. Send Email messages
- B. Send VoiceMail messages
- C. Send VoiceMail & Email messages
- D. Send Recorded names

Answer: B

Explanation:

Cisco Unity can be set up to use AMIS when the target messaging server is another voice-mail server that supports the AMIS-a specification. This provides an analog method for transferring voice messages between different voice-messaging systems. AMIS-a support is available when integrating with Microsoft Exchange. You can use AMIS networking to assist customers in transitioning their legacy voice-mail systems to an IP telephony solution. The industry-standard protocol provides a way for disparate voice-mail systems to exchange messages. The protocol uses DTMF to address and control format, and analog voice to transfer messages. The originating system sets up the call, establishes a connection over the telephone network, and then sends data frames as DTMF tones and voice data as audio to the destination system. The destination system sends response frames as DTMF tones. For each subscriber that is located on another voice-mail system, you add an AMIS subscriber to Cisco Unity. These subscribers are

accessible through the Cisco Unity directory.

An AMIS subscriber has similar attributes to an Exchange custom recipient. AMIS subscribers do not impact Exchange licensing counts because its message store resides on the other voice-mail system. If you have several Cisco Unity servers that are using the same directory and are networked together, only one Cisco Unity server requires licensing for AMIS networking.

The following are supported AMIS-compliant voice-messaging systems with Cisco Unity 4.0(x):

- * Active Voice Repartee
- * Avaya Interchange with AMIS-analog Networking Gateway
- * Avaya INTUITY AUDIX
- * Avaya Octel 100 Messaging
- * Avaya Octel 250/350
- * Centigram Voice Mail
- * Nortel Networks Meridian Mail
- * Siemens PhoneMail

QUESTION 141:

In a CallManager cluster, Intra Cluster Communications Signaling Includes:
(Choose two.)

- A. Registration of devices
- B. Device configuration replication
- C. Locations bandwidth Shared media resources
- D. Call Detail Records (CDR) database replication

Answer:A, B

Explanation:

Two primary types of communication occur within a CiscoCallManager cluster. The first type of intracluster communication provides a mechanism for distributing the database that contains all the device configuration information. When you make configuration changes in CiscoCallManager Administration, the publisher server initially stores those changes in its local database. The publisher then sends the new data to all the subscriber servers in the cluster, so that they can update their local copies of the database. This mechanism ensures that the configuration database remains consistent across all servers in the cluster. It also provides database redundancy because the subscriber servers can continue to operate from their local copies of the database even if the publisher becomes unavailable for any reason.

The second type of intracluster communication involves the propagation and replication of run-time data such as registration of IP phones, gateways, and digital signal processor (DSP) resources. All servers in the cluster share this run-time data, thus ensuring optimum routing of calls between members of the cluster and associated gateways. In large systems, you might have to configure more than one cluster to handle the call

processing load. Communication between the clusters occurs by means of intercluster trunks using H.323 protocol. Most large systems use one of three main types of multicluster configurations:

1. Large, single campus, or metropolitan-area network (MAN)
2. Multisite WAN with distributed call processing (one or more CiscoCallManagers at each site)
3. Multisite WAN with centralized call processing (no Cisco CallManager at the remote site or sites)

Because intercluster trunks in a MAN usually have sufficient bandwidth, they do not require any call admission control mechanism. Multisite WANs with distributed call processing typically use gatekeeper technology for call admission control. Multisite WANs with centralized call processing can use the locations feature in Cisco CallManager to implement call admission control.

Most features of CiscoCallManager do not extend beyond a single cluster, but the following features do exist between clusters:

1. Basic call setup
2. G.711 and G.729 calls
3. Multiparty conference
4. Call hold
5. Call transfer
6. Call park
7. Calling line ID

QUESTION 142:

What is the correct sequence of call setup between a IP phone and a H.323 Client?

- A. Phone A initiates a call to an H.323 Client C via H.323 signaling with Call Manager Z. Call Manager Z performs H.323 signaling (H.225, H.245) with H.323 Client C. Phone A and H.323 Client C stream audio directly between each other.
- B. Phone A initiates a call to an H.323 Client C via H.323 signaling (H.225, H.245) with Call Manager Z. Call Manager Z performs stimulus signaling with H.323 Client C. Phone A and H.323 Client C stream audio directly between each other.
- C. Phone A initiates a call to an H.323 Client C via stimulus signaling with Call Manager Z. Call Manager Z performs H.323 signaling (H.225, H.245) with H.323 Client C. Phone A and H.323 Client C stream audio directly between each other.
- D. Phone A initiates a call to an H.323 Client C via stimulus signaling with Call Manager Z. Call Manager Z performs stimulus signaling with H.323 Client C. Phone A and H.323 Client C stream audio directly between each other.

Answer: C

QUESTION 143:

Unity 4.0 introduces what standards-based protocol to send/receive messages to/from other Vendors Voicemail systems?

- A. OctelNet
- B. E&M
- C. VPIM
- D. AMIS-A

Answer: D

Explanation:

AMIS-A support allows VoIP devices to exchange AMIS-A DTMF tones (A, B, C, and D) with the CiscoCallManager, in an out of band signal. The purpose of AMIS-A support is to facilitate uOne voice mail message exchange with legacy voice mail systems.

AMIS-A DTMF tones (A, B, C, and D) are transported in two different schemes. On the IP side, the tones are detected and generated in an out of band signaling format, whereas on the TDM side of the gateways, the tones are detected and generated inband along with the voice path.

The main role of CiscoCallManager is to make sure that DTMF digits received from the sending device are correctly mapped to the corresponding signal format (or API) of the terminating device.

The following existing APIs are impacted to include the AMIS-A DTMF tones (A, B, C, and D):

1. Skinny Station Protocol-StationKeyPadButton and StationOutputKeyPadButton
2. Skinny Gateway Protocol-GatewayToDeviceReportDigit, DeviceToGatewayPlayTone, and Q.931 and Information message (for analog access gateway).
3. H323 Protocol-H245 User Input Indication (h245-signal)
4. MGCP Protocol-NTFY and RQNT

QUESTION 144:

Which pins are used to supply Inline-Power to an IP Phone when using an Inline-Power enabled Catalyst Switch?

- A. 4,5
- B. 7,8
- C. 4,5,7,8
- D. 1,2,3,6
- E. 1,2

Answer: D

Explanation:

The Catalyst Inline Power Patch Panel can also work in conjunction with the existing

patch-panel configuration. Ethernet terminals use pins 1, 2, 3, and 6 for data transmission, and the Catalyst Inline Power Patch Panel does not access or insert power into these wire pairs. The Catalyst Inline Power Patch Panel acts as a normal patch panel for Ethernet connections that do not require inline power, ensuring reliable performance by keeping unneeded circuitry out of these normal patch-panel connections. The Catalyst Inline Power Patch Panel provides power only on the unused Fast Ethernet pins 4, 5, 7, and 8. Network administrators can count on reliable power distribution that will not interfere with network operations that do not require inline power.

QUESTION 145:

Which pins are used to supply Inline-Power to an IP Phone when using a Cisco Inline-Power Patch-Panel?

- A. 4,5
- B. 7,8
- C. 4,5,7,8
- D. 1,2,3,6
- E. 1,2

Answer: C

Explanation:

The Catalyst Inline Power Patch Panel can also work in conjunction with the existing patch-panel configuration. Ethernet terminals use pins 1, 2, 3, and 6 for data transmission, and the Catalyst Inline Power Patch Panel does not access or insert power into these wire pairs. The Catalyst Inline Power Patch Panel acts as a normal patch panel for Ethernet connections that do not require inline power, ensuring reliable performance by keeping unneeded circuitry out of these normal patch-panel connections. The Catalyst Inline Power Patch Panel provides power only on the unused Fast Ethernet pins 4, 5, 7, and 8. Network administrators can count on reliable power distribution that will not interfere with network operations that do not require inline power.

QUESTION 146:

What protocol does an IP Phone use to learn the Voice VLAN ID it should use for Voice Traffic?

- A. VTP
- B. 802.1q
- C. CDP
- D. Skinny Station Protocol
- E. LLQ

Answer: C

Explanation:

Cisco Discovery Protocol (CDP) is a proprietary protocol designed by Cisco to help administrators collect information about both locally attached and remote devices. By using CDP, you can gather hardware and protocol information about neighbor devices, which is useful info for troubleshooting and documenting the network!

QUESTION 147:

What protocol does an IP Phone use to learn the IP Address of its TFTP Server?

- A. HSRP
- B. DHCP
- C. Skinny Station Protocol
- D. STP
- E. CDP

Answer: B

Explanation:

You can store profiles for all phones on your network on a Trivial File Transfer Protocol (TFTP) server. Phones can then be configured to automatically download their profiles periodically. Alternatively, you can enter parameter values into a web interface designed for that purpose. Both methods are described in this chapter.

If you are not using a Dynamic Host Configuration Protocol (DHCP) server, you must first manually define IP addresses and gateways for the phones.

QUESTION 148:

Exhibit

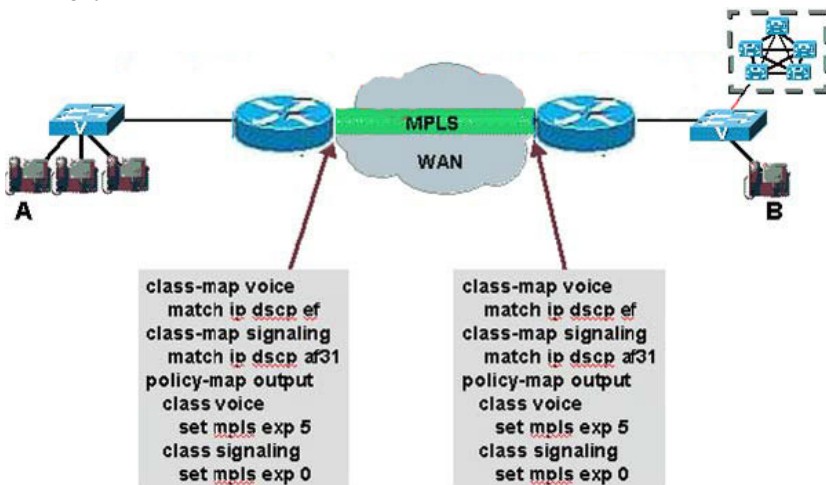

Consider the QoS configuration in the picture shown for a VoIP call across an MPLS network. If IP Phone A calls IP Phone B, how will voice and signaling packets be marked by the time they arrive at the IP Phone B? NOTE: Assume the LAN switches (and any other equipment in the cloud) do not mark or remark the packets, and the complete MPLS router QoS configuration is shown in the picture.

- A. Voice: DSCP EF ; Signaling : DSCP AF31
- B. Voice: DSCP EF ; Signaling : 0
- B. Voice: IP Precedence 5; Signaling : 0
- C. Voice: IP Precedence 5; Signaling : 3
- D. Voice: 0 ; Signaling : 0

Answer: A, D

QUESTION 149:

When using the Low Latency Queuing feature of Cisco IOS:

- A. All the RTP traffic is serviced by the PQ and the data traffic is serviced using the CBWFQ.
- B. All the RTP and data traffic is send to the PQ and serviced according to the IP Precedence.
- C. All the RTP traffic is serviced using the CBWFQ and data traffic is serviced by the PQ.
- D. None of the above

Answer: D

Explanation:

The Low Latency Queueing feature brings strict priority queueing to Class-Based Weighted Fair Queueing (CBWFQ). Strict priority queueing allows delay-sensitive data such as voice to be dequeued and sent first (before packets in other queues are dequeued), giving delay-sensitive data preferential treatment over other traffic.

Without Low Latency Queueing, CBWFQ provides weighted fair queueing based on defined classes with no strict priority queue available for real-time traffic. CBWFQ allows you to define traffic classes and then assign characteristics to that class. For example, you can designate the minimum bandwidth delivered to the class during congestion.

For CBWFQ, the weight for a packet belonging to a specific class is derived from the bandwidth you assigned to the class when you configured it. Therefore, the bandwidth assigned to the packets of a class determines the order in which packets are sent. All packets are serviced fairly based on weight; no class of packets may be granted strict priority. This scheme poses problems for voice traffic that is largely intolerant of delay, especially variation in delay. For voice traffic, variations in delay introduce irregularities of transmission manifesting as jitter in the heard conversation.

The Low Latency Queueing feature provides strict priority queueing for CBWFQ, reducing jitter in voice conversations. Configured by the priority command, Low Latency Queueing enables use of a single, strict priority queue within CBWFQ at the class level, allowing you to direct traffic belonging to a class to the CBWFQ strict priority queue. To enqueue class traffic to the strict priority queue, you configure the priority command for the class after you specify the named class within a policy map. (Classes to which the priority command is applied are considered priority classes.) Within a policy map, you can give one or more classes priority status. When multiple classes within a single policy map are configured as priority classes, all traffic from these classes is enqueued to the same, single, strict priority queue.

One of the ways in which the strict priority queueing used within CBWFQ differs from its use outside CBWFQ is in the parameters it takes. Outside CBWFQ, by using the ip rtp priority command, you specify the range of UDP ports whose voice traffic flows are to be given priority service. Using the priority command, because you can configure the priority status for a class within CBWFQ, you are no longer limited to a UDP port number to stipulate priority flows. Instead, all of the valid match criteria used to specify traffic for a class now applies to priority traffic. These methods of specifying traffic for a class include matching on access lists, protocols, and input interfaces. Moreover, within an access list you can specify that traffic matches are allowed based on the IP Differentiated Services Code Point (DSCP) value that is set using the first six bits of the Type of Service (ToS) byte in the IP header.

QUESTION 150:

Network Topology Exhibit.



Assume Router Certkiller 1 has been correctly configured to allow the phone on the left to call the phone on the right using Voice over IP. If the phone on the left calls the phone on the right using an IP Precedence setting in both directions, what changes should be made to Router Certkiller 2?

- A. Create a default dial-peer VoIP statement with the corresponding IP precedence on Router Certkiller 2 which will be used for all calls without matching destinations patterns
- B. Create a dial-peer VoIP statement on Router Certkiller 2 with a matching destination pattern for Phone Certkiller 1's number and a corresponding IP precedence statement
- C. Create a policy route map using the policy-route command on the inbound serial interface of Router Certkiller 2 that will set the IP precedence by matching the source and destination IP address of Router Certkiller 1 and Router Certkiller 2
- D. Create a committed access rate using the rate-access command on the inbound serial interface of Router Certkiller 2 that will set the IP precedence by matching the source and destination IP address of Router Certkiller 1 and Router Certkiller 2
- E. Use the set-reverse-direction keyword on the IP precedence line in the corresponding dial-peer on Router Certkiller 2

Answer: B

QUESTION 151:

Network topology exhibit

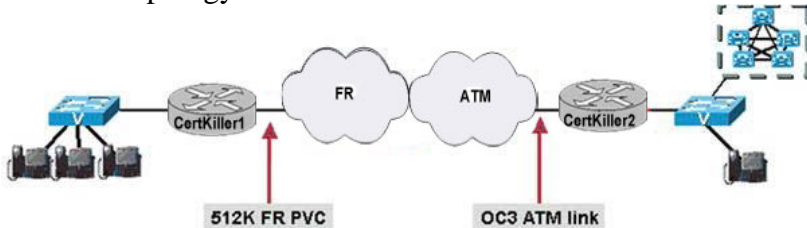

Consider the WAN network in the picture shown. The speed of the FR PVC connecting Router Certkiller 1 to the FR network is such that fragmentation is required when a voice call is present across the WAN. The speed of the ATM PVC connecting Router Certkiller 2 is high enough not to require fragmentation. Which technologies are involved in the QoS solution needed for this scenario.

- A. FRF.12
- B. FRF.8
- C. FRF.5
- D. MLPPP
- E. FRF.16

Answer: A, B

Explanation:

The FRF.12 Support on Switched Frame Relay PVCs feature brings existing end-to-end FRF.12 fragmentation functionality to switched Frame Relay permanent virtual circuits (PVCs).

The FRF.12 Implementation Agreement allows long data frames to be fragmented into smaller pieces. This process allows real-time traffic and non-real-time traffic to be carried together on lower-speed links without causing excessive delay to the real-time traffic.

Some Frame Relay access devices do not support the FRF.12 standard for end-to-end fragmentation. Large packets sourced from these devices can cause significant serialization delay across low-speed trunks in switched networks.

The FRF.12 Support on Switched Frame Relay PVCs feature helps prevent this delay by bringing end-to-end FRF.12 fragmentation to routers that are acting as switches on the edge of switched Frame Relay networks. An edge router that receives large packets from a Frame Relay access device will fragment those packets before transmitting them across the switched network. The edge router that receives the fragmented packets will reassemble those packets before sending them to a Frame Relay access device that does not support FRF.12. If the receiving Frame Relay access device does support FRF.12, the router will transmit the fragmented packets without reassembling them.

FRF.8 Frame Relay to Asynchronous Transfer Mode (ATM) Interworking allows connection of Frame Relay traffic across high-speed ATM trunks using ATM standard Network and Service Interworking. This document describes Frame Relay-to-ATM Service Interworking for data transfer, outlined in Frame Relay Forum implementation agreement FRF.8 and designed for the Cisco MC3810 multiservice access concentrator.

QUESTION 152:

Which standards outline a fragmentation implementation to help control the delay variation when real-time traffic, such as voice, is carried on the same interface as data? (multiple answer)

- A. MLPPP LFI
- B. FRF.12
- C. FRF.11
- D. H.245
- E. H.323

Answer: A, B

Explanation:

The Link Services PIC provides simultaneous support for three separate capabilities: enhanced Multilink bundling, tunneling, and link fragmentation and interleaving (LFI). Supported by the M5M7i, M10i, M20, and M40e and M320 routers, the Link Services PIC can be combined with other IP Services PICs to enhance platform functionality.

1. Enhanced multilink capabilities offered by the Link Services PIC include support for FRF.16 and FRF.15, which facilitates the efficient and cost-effective aggregation and bundling of Frame Relay links. All other capabilities offered by the existing Multilink Services PIC are supported, including FRF.15 and Multilink PPP (MLPPP). MLPPP is also supported, providing PPP over multiple discrete links such as N x T1/E1.

2. Link fragmentation and interleaving (LFI) is designed to optimize converged environments; LFI improves quality of service (QoS) on lower-speed links to ensure a high-quality user experience. An essential feature for service providers offering latency-sensitive services over low-speed links, LFI minimizes delay and jitter that are characteristic of high-payload packets. By breaking up large datagrams resulting from file transfers and interleaving low-latency traffic with the resulting smaller packets, serialization delay is minimized so overall service levels can be significantly improved.

3. The increased capability for granular traffic prioritization enables service providers to offer support for high-revenue delay-sensitive services, such as VoIP and VoD. Service level agreements can be established and stringently policed by utilizing LFI in conjunction with the Channelized IQ-PICs, which are currently offered at E-1, DS3, and OC-12 bandwidths. By policing SLAs across the network, customers are assured of a high-quality end user experience.

4. Tunneling capabilities provided by the Link Services PIC are identical to the services supported by the existing Tunnel Services PIC.

QUESTION 153:

A T1 (1.536M) FR PVC must be configured for voice and data traffic. It is expected that voice will never require more than half of the bandwidth. What is the most appropriate FRTS configuration for this scenario?

- A. map-class frame-relay FRTS-voice
frame-relay cir 1536000
frame-relay bc 15360
frame-relay be 0
frame-relay mincir 1536000
- B. map-class frame-relay FRTS-voice
frame-relay cir 1536000
frame-relay bc 1536
frame-relay be 0
frame-relay mincir 1536000
- C. map-class frame-relay FRTS-voice
frame-relay cir 1536000
frame-relay bc 15360
frame-relay be 1536
frame-relay mincir 1536000
- D. map-class frame-relay FRTS-voice
frame-relay cir 1536000
frame-relay bc 15360
frame-relay be 0
frame-relay mincir 1536000
- E. map-class frame-relay FRTS-voice
frame-relay cir 1536000
frame-relay bc 15360
frame-relay be 0
frame-relay mincir 768000

Answer: E

QUESTION 154:

What is the ITU G.114 specification for one-way delay for Voice?

- A. 50 ms
- B. 100 ms
- C. 150 ms
- D. 200 ms
- E. 250 ms

Answer: C

Explanation:

For VoIP to be a realistic replacement for standard PSTN telephony services, customers need to receive the same quality of voice transmission that they receive with basic telephone services: consistently high-quality voice transmissions. Like other real-time applications, VoIP is extremely bandwidth and delay sensitive. For VoIP transmissions to be intelligible to the receiver, voice packets should not be dropped or excessively delayed, or suffer varying delay (otherwise known as jitter). For example:

* The default G.729 codec requires packet loss far less than 1 percent to avoid audible errors. Ideally, there should be no packet loss for VoIP.

* ITU G.114 specification recommends less than 150 ms one-way end-to-end delay for high-quality real-time traffic, such as voice. (For international calls, one-way delay up to 300 ms is acceptable, especially for satellite transmission. This takes propagation delay into consideration-the time required for the signal to travel the distance.)

* Jitter buffers (used to compensate for varying delay) further add to the end-to-end delay, and are usually effective only on delay variations of less than 100 ms. Jitter must therefore be minimized.

QUESTION 155:

What is MQC?

- A. Modular Quality of Service Command Line Interface
- B. Mean Quality Coefficient
- C. Maximum Quality Carrier
- D. Minimum Quality Call
- E. Maximum Quality Call

Answer: A

Explanation:

The Modular QoS CLI (MQC) Three-Level Hierarchical Policer extends the traffic policing functionality by allowing you to configure traffic policing at three levels of policy map hierarchies; a primary level, a secondary level, and a tertiary level. Traffic policing may be configured at any or all of these levels, depending on the needs of your network. Configuring traffic policing in a three-level hierarchical structure provides a high degree of granularity for traffic policing.

Modular Quality of Service Command-Line Interface (MQC)The MQC is a command-line interface (CLI) structure that allows you to create traffic policies and attach these policies to interfaces.

In the MQC, the class-map command is used to define a traffic class (which is then associated with a traffic policy). The purpose of a traffic class is to classify traffic. The Modular quality of service (QoS) CLI structure consists of the following three

processes:

Defining a traffic class with the class-map command.

Creating a traffic policy by associating the traffic class with one or more QoS features (using the policy-map command).

Attaching the traffic policy to the interface with the service-policy command.

A traffic class contains three major elements: a name, a series of match commands, and, if more than one match command exists in the traffic class, an instruction on how to evaluate these match commands. The traffic class is named in the class-map command line; that is, if you enter the class-map cisco command while configuring the traffic class in the CLI, the traffic class would be named "cisco".

The match commands are used to specify various criteria for classifying packets. Packets are checked to determine whether they match the criteria specified in the match commands. If a packet matches the specified criteria, that packet is considered a member of the class and is forwarded according to the QoS specifications set in the traffic policy. Packets that fail to meet any of the matching criteria are classified as members of the default traffic class.

QUESTION 156:

On average, how much Layer 3 is required for Call Control for an IP Phone?

- A. 150 bps
- B. 600 bps
- C. 2 kbps
- D. 4 kbps
- E. 8 kbps

Answer: A

Explanation:

The following list summarizes the key QoS requirements and recommendations for Call-Signaling traffic:

* Call-Signaling traffic should be marked as DSCP CS3 per the QoS Baseline (during migration, it also can be marked the legacy value of DSCP AF31).

* 150 bps (plus Layer 2 overhead) per phone of guaranteed bandwidth is required for voice control traffic; more may be required, depending on the Call-Signaling protocol(s) in use.

Originally, Cisco IP Telephony equipment marked Call-Signaling traffic to DSCP AF31. However, the assured forwarding classes, as defined in RFC 2597, were intended for flows that could be subject to markdown and aggressive dropping of marked-down values. Marking down and aggressively dropping Call-Signaling could result in noticeable delay todial tone (DDT) and lengthy call-setup times, both of which generally translate into poor user experiences.

Therefore, the QoS Baseline changed the marking recommendation for Call-Signaling traffic to DSCP CS3 because Class-Selector code points, defined in RFC 2474, are not

subject to such markdown and aggressive dropping as Assured Forwarding Per-Hop Behaviors are.

Some Cisco IP Telephony products already have begun transitioning to DSCP CS3 for Call-Signaling marking. In this interim period, both code points (CS3 and AF31) should be reserved for Call-Signaling marking until the transition is complete.

Most Cisco IP Telephony products use the Skinny Call-Control Protocol (SCCP) for Call-Signaling. Skinny is a relatively lightweight protocol and, as such, requires only a minimal amount of bandwidth protection (most of the Cisco large-scale lab testing was done by provisioning only 2 percent for Call-Signaling traffic over WAN and VPN links). However, newer versions of CallManager and SCCP have shown some "bloating" in this signaling protocol, so design recommendations have been adjusted to match (most examples in the design chapters that follow have been adjusted to allocate 5 percent for Call-Signaling traffic). This is a normal part of QoS evolution: As applications and protocols continue to evolve, so do the QoS designs required to accommodate them.

QUESTION 157:

The difference between Type of Service (ToS) and Class of Service (CoS) is:

- A. CoS is a field in the IP header, but ToS is evaluated by the routing protocol.
- B. CoS allows a class based access to the media, but ToS is a field in the IP header.
- C. CoS allows a class based access to the media, but ToS prioritizes this access according to the precedence bit.
- D. CoS is a layer 2 mechanism, but ToS is a layer 3 mechanism.

Answer: D

CoS Layer 2

<http://www.cisco.com/univercd/cc/td/doc/product/software/ios120/120newft/120limit/120s/120s28/12swred.htm>

ToS Layer 3

http://www.cisco.com/en/US/products/hw/switches/ps672/products_qanda_item09186a00800a8922.shtml

QUESTION 158:

Which queueing algorithms are recommended for Voice, Call Control and generic data traffic (respectively)?

- A. Priority Queueing, Custom-Queueing, Weighted-Fair Queueing
- B. Low-Latency Queueing, Class-Based Weighted-Fair Queueing and Weighted-Fair Queueing
- C. Low-Latency Queueing, Class-Based Weighted-Fair Queueing and Default Queueing
- D. Priority Queueing, Bandwidth Queueing and Fair Queueing
- E. Low-Latency Queueing, Class-Based Weighted-Fair Queueing and Fair Queueing

Answer: B

Explanation:

1. Weighted-Fair Queuing:

When FIFO queuing is in effect, traffic is transmitted in the order received without regard for bandwidth consumption or the associated delays. File transfers and other high-volume network applications often generate series of packets of associated data known as packet trains. Packet trains are groups of packets that tend to move together through the network. These packet trains can consume all available bandwidth, and other traffic flows back up behind them.

Weighted fair queuing overcomes an important limitation of FIFO queuing. Weighted fair queuing is an automated method that provides fair bandwidth allocation to all network traffic. Weighted fair queuing provides traffic priority management that dynamically sorts traffic into conversations, or flows. Weighted fair queuing then breaks up a stream of packets within each conversation to ensure that bandwidth is shared fairly between individual conversations. There are four types of weighted fair queuing: flow-based, distributed, class-based, and distributed class-based.

Weighted fair queuing (WFQ) is a flow-based algorithm that schedules delay-sensitive traffic to the front of a queue to reduce response time, and also shares the remaining bandwidth fairly among high-bandwidth flows. By breaking up packet trains, WFQ assures that low-volume traffic is transferred in a timely fashion. Weighted fair queuing gives low-volume traffic, such as Telnet sessions, priority over high-volume traffic, such as File Transfer Protocol (FTP) sessions. Weighted fair queuing gives concurrent file transfers balanced use of link capacity. Weighted fair queuing automatically adapts to changing network traffic conditions.

2. Class-based Weighted-Fair Queuing:

Class-based weighted fair queuing (CBWFQ) extends the standard WFQ functionality to provide support for user-defined traffic classes. By using CBWFQ, network managers can define traffic classes based on several match criteria, including protocols, access control lists (ACLs), and input interfaces. A FIFO queue is reserved for each class, and traffic belonging to a class is directed to the queue for that class. More than one IP flow, or "conversation", can belong to a class.

Once a class has been defined according to its match criteria, the characteristics can be assigned to the class. To characterize a class, assign the bandwidth and maximum packet limit. The bandwidth assigned to a class is the guaranteed bandwidth given to the class during congestion.

CBWFQ assigns a weight to each configured class instead of each flow. This weight is proportional to the bandwidth configured for each class. Weight is equal to the interface bandwidth divided by the class bandwidth. Therefore, a class with a higher bandwidth value will have a lower weight

3. LLQ

The Low Latency Queuing (LLQ) feature provides strict priority queuing for class-based weighted fair queuing (CBWFQ), reducing jitter in voice conversations. Configured by the priority command, strict priority queuing gives delay-sensitive data, such as voice, preferential treatment over other traffic. With this feature, delay-sensitive data is sent first, before packets in other queues are treated. LLQ is also referred to as priority

queuing/class-based weighted fair queuing (PQ/CBWFQ) because it is a combination of the two techniques.

QUESTION 159:

What is the best configuration for provisioning for VoIP at the WAN Edge?

- A. !
version 12.2
!
class-map match-all VOICE
match ip rtp 16384 32767
class-map match-all VOICE-CONTROL
match protocol skinny
!
policy-map WAN-EDGE
class VOICE
low-latency queueing 33 percent
class VOICE-CONTROL
class-based queueing 2 percent
class class-default
weighted-fair-queue
!
- B. !
version 12.2
!
class-map match-all VOICE
match ip dscp ef
class-map match-all VOICE-CONTROL
match ip dscp af31
!
policy-map WAN-EDGE
class VOICE
priority percent 33
class VOICE-CONTROL
bandwidth percent 2
class class-default
fair-queue
!
- C. !
version 12.2
!
class-map match-all VOICE
match ip dscp 5
class-map match-all VOICE-CONTROL

```
match ip dscp 3
!  
policy-map WAN-EDGE  
class VOICE  
priority percent 33  
class VOICE-CONTROL  
bandwidth percent 2  
class class-default  
fair-queue  
!  
D. !  
version 12.2  
!  
class-map match-all VOICE  
match ip dscp 46  
class-map match-all VOICE-CONTROL  
match ip dscp 26  
!  
policy-map WAN-EDGE  
class VOICE  
priority queue 33 percent  
class VOICE-CONTROL  
bandwidth queue 2 percent  
class class-default  
fair-queue  
!
```

Answer: B

Explanation:

Voice quality is directly affected by all three QoS quality factors such as loss, delay, and delay variation.

Loss causes voice clipping and skips. Industry standard codec algorithms can correct for up to 30 ms of lost voice. Cisco Voice over IP (VoIP) technology uses 20 ms samples of voice payload per VoIP packet. Only a single Real Time Transport (RTP) packet could be lost at any given time. If two successive voice packets are lost, the 30 ms correctable window is exceeded and voice quality begins to degrade.

Delay can cause voice quality degradation if it is above 200 ms. If the end-to-end voice delay becomes too long, the conversation sounds as if two parties are talking over a satellite link or a CB radio. The ITU standard for VoIP, G.114, states that a 150 ms one-way delay budget is acceptable for high voice quality.

With respect to delay variation, there are adaptive jitter buffers within IP Telephony devices. These buffers can usually compensate for 20 to 50 ms of jitter.

QUESTION 160:

What is the optimal recommended interval for traffic-shaping converged Frame-Relay circuits on non-distributed platforms and how is this set?

- A. 8 ms Interval set by configuring Bc to equal CIR/125
- B. 8 ms Interval set by configuring Be to equal CIR/125
- C. 10 ms Interval set by configuring Bc to equal CIR/100
- D. 10 ms Interval set by configuring Be to equal CIR/100
- E. 12.5 ms Interval set by configuring Bc to equal CIR/80
- F. 12.5 ms Interval set by configuring Be to equal CIR/80

Answer: C

Explanation:

Traffic Shaping for Voice Use these guidelines when you configure traffic shaping for voice:

- * Do not exceed the CIR of the PVC.
- * Disable Frame Relay adaptive shaping.
- * Set the Bc value low so Tc (shaping interval) is 10 ms ($Tc = Bc/CIR$). Configure the Bc value to force the desired Tc value.
- * Set the Be value to 0.

Reference: <http://www.cisco.com/warp/public/788/voice-qos/voip-ov-fr-qos.html>

QUESTION 161:

How many bytes are saved per VoIP packet by enabling cRTP on a standard G.711 call?

- A. 2-5 bytes per VoIP packet
- B. 12-15 bytes per VoIP packet
- C. 22-35 bytes per VoIP packet
- D. 35-38 bytes per VoIP packet
- E. 42-45 bytes per VoIP packet

Answer: D

Explanation:

Two basic variations of 64 Kbps PCM are commonly used: μ -law and a-law. The methods are similar in that they both use logarithmic compression to achieve 12 to 13 bits of linear PCM quality in 8 bits, but they are different in relatively minor compression details (μ -law has a slight advantage in low-level, signal-to-noise ratio performance). Usage is historically along country and regional boundaries, with North America using μ -law and Europe and other countries using a-law modulation. It is important to note that when making a long-distance call, any required μ -law to a-law conversion is the responsibility of the μ -law country.

Another compression method used often is adaptive differential pulse code modulation (ADPCM). A commonly used instance of ADPCM is ITU-T G.726, which encodes using 4-bit samples, giving a transmission rate of 32 Kbps. Unlike PCM, the 4 bits do not directly encode the amplitude of speech, but they do encode the differences in amplitude, as well as the rate of change of that amplitude, employing some rudimentary linear prediction.

PCM and ADPCM are examples of waveform codecs-compression techniques that exploit redundant characteristics of the waveform itself. New compression techniques were developed over the past 10 to 15 years that further exploit knowledge of the source characteristics of speech generation. These techniques employ signal processing procedures that compress speech by sending only simplified parametric information about the original speech excitation and vocal tract shaping, requiring less bandwidth to transmit that information.

These techniques can be grouped together generally as source codecs and include variations such as linear predictive coding (LPC), code excited linear prediction compression (CELP), and multipulse, multilevel quantization (MP-MLQ).

Voice Coding StandardsThe ITU-T standardizes CELP, MP-MLQ PCM, and ADPCM coding schemes in its G-series recommendations. The most popular voice coding standards for telephony and packet voice include:

1. G.711 -Describes the 64 Kbps PCM voice coding technique outlined earlier; G.711-encoded voice is already in the correct format for digital voice delivery in the public phone network or through Private Branch eXchanges (PBXs).
2. G.726 -Describes ADPCM coding at 40, 32, 24, and 16 Kbps; you also can interchange ADPCM voice between packet voice and public phone or PBX networks, provided that the latter has ADPCM capability.
3. G.728 -Describes a 16 Kbps low-delay variation of CELP voice compression.
4. G.729 -Describes CELP compression that enables voice to be coded into 8 Kbps streams; two variations of this standard (G.729 and G.729 Annex A) differ largely in computational complexity, and both generally provide speech quality as good as that of 32 Kbps ADPCM.
5. G.723.1 -Describes a compression technique that you can use to compress speech or other audio signal components of multimedia service at a low bit rate, as part of the overall H.324 family of standards. Two bit rates are associated with this coder: 5.3 and 6.3 Kbps. The higher bit rate is based on MP-MLQ technology and provides greater quality. The lower bit rate is based on CELP, provides good quality, and affords system designers with additional flexibility.
6. iLBC (Internet Low Bitrate Codec) -A free speech codec suitable for robust voice communication over IP. The codec is designed for narrow band speech and results in a payload bit rate of 13.33 kbps with an encoding frame length of 30 ms and 15.20 kbps with an encoding length of 20 ms. The iLBC codec enables graceful speech quality degradation in the case of lost frames, which occurs in connection with lost or delayed IP packets. The basic quality is higher than G.729A, with high robustness to packet loss. The PacketCable consortium and many vendors have adopted iLBC as a preferred codec. It is also being used by many PC-to-Phone applications, such as Skype, Google Talk, Yahoo! Messenger with Voice, and MSN Messenger.

QUESTION 162:

What Network Management Server (NMS) application leverages the Service Assurance Agent within IOS to gather statistics on VoIP latency, jitter and loss?

- A. Resource Manager Essentials
- B. Device Fault Monitor
- C. Voice Health Monitor
- D. Internetwork Performance Monitor
- E. Quality of Service Policy Manager

Answer: D

Explanation:

Internetwork Performance Monitor is a network response time and availability troubleshooting application. It allows network administrators to proactively troubleshoot end-to-end network performance problems to locate and diagnose congestion and latency problems utilizing real time and historical statistics. IPM is available as a component within the CiscoWorks LAN Management Solution (LMS). As such, it can draw on device inventory information maintained by the CiscoWorks base applications.

QUESTION 163:

Pulse Code Modulation (PCM) sampling rate was specified by Nyquist to accurately recreate the voice signal on the opposite end. What is the sample rate used in PCM?

- A. 4000 per second
- B. 8000 per second
- C. 16000 per second
- D. 64000 per second

Answer: B

Explanation:

PCM converts analog sound into digital form by sampling the analog sound 8000 times per second and converting each sample into a numeric code. The Nyquist theorem states that if you sample an analog signal at twice the rate of the highest frequency of interest, you can accurately reconstruct that signal back into its analog form. Because most speech content is below 4000 Hz (4 kHz), a sampling rate of 8000 times per second (125 microseconds between samples) is required.

QUESTION 164:

What statement regarding G.729 is correct?

- A. G.729 has an algorithmic delay of about 10 milliseconds. In the Cisco IOS Voice over IP (VoIP) product, the DSP generates a frame every 10 milliseconds. Each speech frame is then placed within one packet; the packet delay is, therefore, 10 milliseconds.
- B. G.729 has an algorithmic delay of about 20 milliseconds. In the Cisco IOS Voice over IP product, the DSP generates a frame every 10 milliseconds. Two of these speech frames are then placed within one packet; the packet delay is therefore, 20 milliseconds.
- C. G.729 has an algorithmic delay of about 30 milliseconds. In the Cisco IOS voice over IP product, the DSP generates a frame every 10 milliseconds. Three of these speech frames are then placed within one packet; the packet delay is therefore, 30 milliseconds.
- D. G.729 has an algorithmic delay of about 20 milliseconds. In the Cisco IOS voice over IP product, the DSP generates a frame every 20 milliseconds. Each speech frame is then placed within one packet; the packet delay is therefore, 20 milliseconds.

Answer: B

Explanation:

A Sampling Example for Satellite Networks Satellite networks have an inherent delay of around 500 ms. This includes 250 ms for the trip up to the satellite, and another 250 ms for the trip back to Earth. In this type of network, packet loss is highly controlled due to the expense of bandwidth. Also, if some type of voice application is already running through the satellite, the users of this service are accustomed to a quality of voice that has excessive delays.

Cisco IOS, by default, sends two 10-ms G.729 speech frames in every packet. Although this is acceptable for most applications, this might not be the best method for utilizing the expensive bandwidth on a satellite link. The simple explanation for wasting bandwidth is that a header exists for every packet. The more speech frames you put into a packet, the fewer headers you require.

If you take the satellite example and use four 10-ms G.729 speech frames per packet, you can cut by half the number of headers you use. Table 7-1 clearly shows the difference between the various frames per packet. With only a 20-byte increase in packet size (20 extra bytes equals two 10 ms G.729 samples), you carry twice as much speech with the packet.

Table 7-1. Frames per Packet (G.729)

G.729 Samples per Frame	IP/RTP/UDP Header	Bandwidth Consumed	Latency
Default (two samples per frame)	40 bytes	24,000 bps	25 ms
Satellite (four samples per frame)	40 bytes	16,000 bps	45 ms

Low Latency (one sample per frame)	40 bytes	40,000 bps	15 ms
--	----------	------------	-------

QUESTION 165:

Based upon Cisco's design guide, using a G.729 codec, and no header compression, what is the typical bandwidth needed for a single VoIP call (including layer 2)?

- A. 8 KBps
- B. 10 KBps
- C. 16 KBps
- D. 24 KBps
- E. 32 KBps

Answer: E

Explanation:

G.729 -Describes CELP compression that enables voice to be coded into 8 Kbps streams; two variations of this standard (G.729 and G.729 Annex A) differ largely in computational complexity, and both generally provide speech quality as good as that of 32 Kbps ADPCM.

QUESTION 166:

If Direct Inward Dialing (DID or DDI) is required by the customer, what signaling type can be considered for implementation to meet this requirement?

- A. T1 CAS
- B. Analog E&M
- C. T1/E1 PRI
- D. E1 R2
- E. All of the above

Answer: E

QUESTION 167:

What statement is correct regarding the "Fax Relay?"

A. Fax Relay is a real-time fax over the packet network. A call starts as a voice call, and upon detecting the v.21 flags from the answering fax machine, the call is switched to fax relay. There is a dial peer configuration that is applicable to fax relay known as fax-rate.

B. Fax Relay is similar to Store & Forward Fax. A call starts as a voice call, and upon detecting the v.21 flags from the answering fax machine, the call is switched to fax relay.

C. Fax Relay is a real-time fax over the packet network. A call starts as a voice call, and upon detecting the v.90 flags from the answering fax machine, the call is switched to fax relay.

D. Fax Relay is a real-time fax over the packet network. A call starts as a voice call, and upon detecting the T.30 flags from the answering fax machine, the call is switched to fax relay.

E. Fax Relay is an asynchronous-time fax over the packet network. A call starts as a voice call, and upon detecting the T.120 flags from the answering fax machine, the call is switched to fax relay.

Answer: A

Explanation:

Cisco provides two methods for fax relay. One method is a Cisco-proprietary method called Cisco fax relay, and it is described in this chapter. The second method is based on the ITU-T T.38 standard, and it is described in Chapter 4.

Fax relay is the default mode for passing faxes through a VoIP network, and Cisco fax relay is the default fax relay type on Cisco voice gateways. This capability has been supported in CiscoIOS Release 11.3 and later releases and is widely available. Cisco fax relay uses Real-Time Transport Protocol (RTP) to transport the fax data.

Cisco fax relay is configured on the VoIP dial peers that direct calls into and out of the packet network. Cisco fax relay can be configured under the H.323 and Session Initiation Protocol (SIP) call control protocols.

Cisco fax relay supports fax relay packet loss concealment, which is a technique that allows gateways to disregard packet loss rates that might otherwise cause fax failures. High-end fax machines with the memory to store page data often are able to use Error Correction Mode (ECM) for error-free page transmission. When ECM is enabled, a fax page is transmitted in a series of blocks that contain frames with packets of data. After receiving the data for a complete page, a receiving fax machine notifies the transmitting fax machine of any frames with errors. The transmitting fax machine then retransmits the specified frames. This process is repeated until all frames are received without errors. If the receiving fax machine is unable to receive an error-free page, the fax transmission may fail and one of the fax machines may disconnect. On networks that have a packet loss rate greater than 2 per cent, fax transmissions routinely fail when ECM is enabled because of ECM's low tolerance for packet loss.

For Details:

<http://www.cisco.com/univercd/cc/td/doc/product/software/ios122/122newft/122t/122t11/faxapp/cisrly.htm>

http://www.cisco.com/en/US/products/sw/iosswrel/ps5207/products_configuration_guide_chapter09186a00805

3

QUESTION 168:

The most important functions of H.245 include: (multiple answer)

- A. Coder/ Decoder (CODEC) type negotiation such as G.711, between the calling and called parties
- B. Both sides of the call perform IP address exchange and UDP port negotiation.
- C. Both sides of the call perform H.225 port negotiation.
- D. Both sides of the call perform IP port negotiation.

Answer: A, B

Explanation:

At the time of writing of the "SAFE: IP Telephony Security in Depth" whitepaper, these were the three predominant protocol standards for voice over IP (VoIP):

- * H.323
- * Session Initiation Protocol (SIP)
- * Media Gateway Control Protocol (MGCP)

The following sections describe each standard in detail.

H.323The International Telecommunication Union (ITU) H.323 standard covers IP devices that participate in and control H.323 sessions, along with elements that interact with switched-circuit networks. This standard does not cover the LAN itself or the transport layer within the network. H.323 provides for point-to-point or multipoint sessions. The H.323 standard is composed of several components, including other standards that describe call control, signaling, registration, and packetization/synchronization of media streams. Table lists these components.

Component	Function
H.225	Specifies messages for call control, signaling, registration, admission, packetization, and synchronization
H.245	Specifies the requirements for opening and closing channels for media streams and other commands
Component	Function
H.261	Video codec for audiovisual services
H.263	Specification for a new video codec for basic video telephone service
G.711	Audio codec-3.1 kHz at 48, 56, and 64 kbps (normal telephony)
G.722	Audio codec-7 kHz at 48, 56, and 64 kbps
G.723	Audio codec-5.3 kbps and 6.3 kbps modes
G.728	Audio codec-3.1 kHz at 16 kbps
G.729	Audio codec-3.1 kHz at 8 kbps

Ports used for H.245 signaling and media channels dynamically are negotiated between the endpoints. This makes it especially difficult to impose security policy and traffic shaping. Additionally, the control channel of H.245 uses TCP as a transport protocol, but

the media stream channels utilize UDP as a transport protocol. For a firewall to be placed between two (or more) H.323 endpoints, the firewall must be either H.323 enabled (that is, it must be intelligent enough to allow H.323 traffic through, appropriately utilizing an H.323 proxy) or it must monitor the control channel to determine which dynamic ports are in use for the H.323 sessions.

QUESTION 169:

In VoIP, once TCP receives a request for opening a voice channel on port 1720, a new TCP port is allocated for (Note assume no Fast Start):

- A. H.225 call setup negotiation
- B. H.245 capability exchange negotiation
- C. H.323 call setup negotiation
- D. UDP port negotiation
- E. G.726 call compression

Answer: B

Explanation:

Ports used for H.245 signaling and media channels dynamically are negotiated between the endpoints. This makes it especially difficult to impose security policy and traffic shaping. Additionally, the control channel of H.245 uses TCP as a transport protocol, but the media stream channels utilize UDP as a transport protocol. For a firewall to be placed between two (or more) H.323 endpoints, the firewall must be either H.323 enabled (that is, it must be intelligent enough to allow H.323 traffic through, appropriately utilizing an H.323 proxy) or it must monitor the control channel to determine which dynamic ports are in use for the H.323 sessions.

QUESTION 170:

The range of UDP port numbers used in Cisco's VoIP implementation is:

- A. 225 to 245
- B. 16384 to 32767
- C. 1718 to 1720
- D. 11000 to 12000
- E. 32768 to 64535

Answer: B

Explanation:

Cisco's VoIP actually uses a number of other UDP ports besides this range, however this range is exactly what Cisco uses as the default range for RTP ports.

QUESTION 171:

Compressed Real-Time Transport Protocol (CRTP) is used on a link-by-link basis to compress the:

- A. IP/UDP/RTP header from 44 bytes to 2-4 bytes most of the time
- B. IP/RTP header from 44 bytes to 6-8 bytes most of the time
- C. IP/UDP/RTP header from 40 bytes to 2-4 bytes most of the time
- D. IP/UDP header from 66 bytes to 2-4 bytes most of the time
- E. All of the above as it depends on the application type

Answer: C

Explanation:

Compressed Real-Time Transport Protocol, or CRTP, is used on a link-by-link basis to compress the IP/UDP/RTP from 40 bytes to 2-4 bytes most of the time. In a packet voice environment when framing speech samples every 20 milliseconds, this scenario generates a payload of 20 bytes. The total packet size comprises an IP header (20 bytes), a UDP header (8 bytes), and an RTP header (12 bytes) combined with a payload of 20 bytes. It is evident that the size of the header is twice the size of the payload. When generating packets every 20 milliseconds on a slow link, the header consumes a large portion of the bandwidth. To avoid the unnecessary consumption of available bandwidth, CRTP is used on a link-by-link basis. This compression scheme reduces the IP/UDP/RTP header to 2 bytes most of the time when no UDP checksums are being sent, or 4 bytes when UDP checksums are used.

QUESTION 172:

H.225 utilizes a scaled-down version of what protocol that is used to set up the connection between two H.323 endpoints?

- A. Q.931
- B. Q.Sig
- C. SS7
- D. Frame Relay SVC signaling
- E. ATM UNI signaling

Answer: A

Explanation:

An H.323 terminal is an endpoint in the LAN that participates in real-time, two-way communications with another H.323 terminal, gateway, or multipoint control unit (MCU). A terminal must support audio communication and can also support audio with

video, audio with data, or a combination of all three.

H.323 terminals must support the following standards and protocols:

1. H.245-An ITU standard used by the terminal to negotiate its use usage of the channel. The H.245 control channel provides in-band reliable transport for capabilities exchange, mode preference from the receiving end, logical channel signaling, and control and indication. Part of the capabilities exchange includes specifying which coder-decoders (CODECs) are available. Recommended audio CODECs include G.711, G.722, G.723, G.723.1, G.728, and G.729. Recommended video CODECs include H.261 and H.263.
2. H.225.0-An ITU standard that uses a variant of Q.931 to set up the connection between two H.323 endpoints.
3. RAS-(Registration Admission Status) A protocol used to communicate with the H.323 gatekeeper.
- 4.

RTP and RTCP-(Real-Time Transport Protocol and Real-Time Control Protocol) Protocols used to sequence the audio and video packets. The RTP header contains a time stamp and sequence number, allowing the receiving device to buffer as much as necessary to remove jitter and latency by synchronizing the packets to play back a continuous stream of sound. RTCP controls RTP and gathers reliability information and periodically passes this information onto session participants.

QUESTION 173:

What standard defines the supplementary service for ISDN?

- A. Q.931
- B. Q.822
- C. Q.932
- D. Q.930
- E. Q.742

Answer: C

Explanation:

Q.932 - Digital Subscriber Signaling System No. 1 (DSS 1) - Generic Procedures for the Control of ISDN Supplementary Services.

QUESTION 174:

What issue is most commonly encountered with an analog Foreign Exchange Office (FXO) loopstart port connection to PBX?

- A. Disconnect supervision
- B. Battery reversal
- C. Busy tone

D. On-hook and off-hook issues

Answer: A

QUESTION 175:

What interface does SMDI traditionally use?

- A. Serial
- B. Parallel
- C. Ethernet
- D. Firewire
- E. USB

Answer: A

Explanation:

Most voice-mail systems relying on an EIA/TIA-232 serial cable (previously known as a RS-232 cable) to communicate with phone systems only have one serial port. You can achieve CMI redundancy by running two or more copies of the Cisco Messaging Interface service on different servers in a CiscoCallManager cluster and using additional hardware including a data splitter.

QUESTION 176:

AAA Can NOT be used for: (multiple answer)

- A. Unified messaging
- B. Admission
- C. Authentication
- D. Security
- E. Architecture
- F. Administration
- G. Billing

Answer: A, B, E, F

Explanation:

Authentication, authorization, and accounting (AAA) is a way to control who is allowed to access your network (authenticate), what they can do while they are there (authorize), and to audit what actions they performed while accessing the network (accounting). AAA can be used in Internet Protocol Security (IPSec) to provide preshared keys during the Internet Security Association and Key Management Protocol (ISAKMP) process or to provide per-user authentication, known as XAUTH, during ISAKMP. AAA can be used to provide a mechanism for authorizing commands that administrators enter at the

command line of a Cisco device. This is called command-line authorization. AAA is also seen in a Virtual Private Dial-Up Networking (VPDN) tunnel set up between two routers.

QUESTION 177:

A voice gateway processing 100 calls in the busy hour averaging six minutes each would be equivalent to:

- A. 100 Erlangs
- B. 360 CCS (call centum seconds)
- C. 10 Erlangs
- D. 60 Erlangs
- E. B and C

Answer: E

QUESTION 178:

In an IP Contact Center deployment, the Erlang-B Traffic Model is used to provision the following resources:

- A. Agents receiving/handling inbound calls
- B. Ports on a voice gateway interfacing to the PSTN
- C. Ports on an IP-IVR interfacing with Cisco CallManager
- D. B and C
- E. None of the above

Answer: D

QUESTION 179:

In a call center deployment, busy hour traffic for voice gateway port/trunk is based upon:

- A. Agent talk time (the time agent spends talking to a caller)
- B. Agent after call work time (AKA "agent wrap up time")
- C. Queue time (the time caller spends waiting in queue waiting for an agent to become available)
- D. A and C
- E. All of the above

Answer: D

QUESTION 180:

A Cisco H.323 gatekeeper can resolve an address using:

- A. An H.323 ID
- B. An E.164 address
- C. An Email-ID
- D. A URL
- E. Any of the above

Answer: B

Explanation:

Mandatory Gatekeeper Functions* Address Translation-Translates H.323 IDs (such as gwyl@domain.com) and E.164 numbers (standard telephone numbers) to endpoint IP addresses.

* Admission Control-Controls endpoint admission into the H.323 network. In order to achieve this, the gatekeeper uses these:

- o H.225 Registration, Admission, and Status (RAS) messages
- o Admission Request (ARQ)
- o Admission Confirm (ACF)
- o Admission Reject (ARJ)

* Bandwidth Control-Consists of managing endpoint bandwidth requirements. In order to achieve this, the gatekeeper uses these H.225 RAS messages:

- o Bandwidth Request (BRQ)
- o Bandwidth Confirm (BCF)
- o Bandwidth Reject (BRJ)

* Zone Management-The gatekeeper provides zone management for all registered endpoints in the zone. For example, controlling the endpoint registration process.

Reference: <http://www.cisco.com/warp/public/788/voip/understand-gatekeepers.html>

QUESTION 181:

A Registration Request (RRQ) Registration, Admission, and Status (RAS) message is NOT sent by what endpoint?

- A. H.323 Gateway
- B. Gatekeeper
- C. H.323 Terminal
- D. Proxy

Answer: B

Explanation:

A gatekeeper is an H.323 entity on the network that provides services such as address translation and network access control for H.323 terminals, gateways, and MCUs. Also, they can provide other services such as bandwidth management, accounting, and dial plans that you can centralize in order to provide scalability.

Gatekeepers are logically separated from H.323 endpoints such as terminals and gateways. They are optional in an H.323 network. But if a gatekeeper is present, endpoints must use the services provided.

QUESTION 182:

In a remote office in a CM network, which types of call processing functions do SRST preserve? Select all that apply.

- A. IP phone to IP Phone calls
- B. IP Phone to conference DSP resources
- C. CTI applications such as IP SoftPhones
- D. IP Phone to Vmail transcoding services
- E. IP Phone to GW calls

Answer: A, C, E

Explanation:

A, D: SRST preserve IP-to-IP calls (local calls), IP-to-PSTN calls and global Voicemail calls.

E: CME/SRST 4.0 added support for CTI applications like Softphone.

QUESTION 183:



A user at Phone Certkiller 1 finishes a call. Later, he notes that "CM Fallback Service Operating" is displayed on Phone Certkiller 1. Which are possible explanations for this?

Select all that apply.

- A. The TCP connection between phone Certkiller 1 and call manager has been disrupted.
- B. Remote-GW has not received any messages from CallManager within the appropriate timeout period.
- C. The FE on Remote-GW is out of service.
- D. The FXO port on Remote-GW is out of service.
- E. The FE on HQ-GW is out of service.

Answer: A, B, C E

QUESTION 184:

Exhibit:

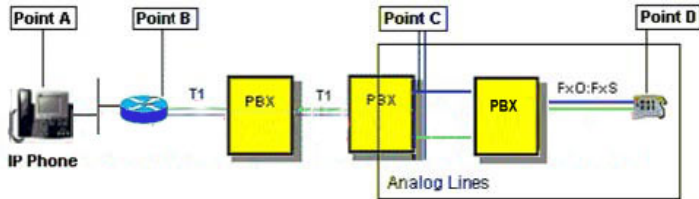

In the diagram shown, what section of the voice path represents the Tail Circuit?

- A. Between Point A and Point B
- B. Between Point C and Point D
- C. Between Point A and Point D
- D. Between Point B and Point D

Answer: D

QUESTION 185:

When troubleshooting a FailSafe problem in Unity, the first place you should look for detailed error messages is the:

- A. tempu.log
- B. System Log
- C. Application Log
- D. SDL Trace
- E. Status Monitor

Answer: C

QUESTION 186:

PRI is the preferred method for inter-connecting CallManager 3.2 and below to PBX's because:

- A. It is the cheapest solution available
- B. It offers the highest level of inter-operability currently available between CallManager and PBX's
- C. It allows a customer to share their existing Voicemail system with CallManager subscribers whilst delivering full functionality

D. Caller ID is available

Answer: A, B

Explanation: A would be more correct than D.

QUESTION 187:

In an AVVID environment, where admission control is handled through the configuration of locations, a g711 call reserves the following amount of bandwidth:

- A. 100
- B. 64
- C. 24
- D. 80

Answer: D

QUESTION 188:

In a distributed AVVID call-processing model, an IOS gatekeeper is used for call Admission Control. What function does the IOS gatekeeper perform?

- A. The gatekeeper will send an ARQ if there is enough available bandwidth.
- B. The gatekeeper will send an ACF if there is enough available bandwidth.
- C. The gatekeeper will send an LRQ message to another gatekeeper if there is not enough bandwidth.
- D. The gatekeeper will fall back to the PSTN if there is not enough bandwidth.

Answer: B

QUESTION 189:

In AVVID architecture, what happens if the TFTP server goes down? Select two.

- A. All the phones will un-register from the CallManager because they cannot download their configuration.
- B. If a phone is reset, it will fail to register again.
- C. New phones plugged to the network will fail to register.
- D. All the existing phones in the network will stay operational.

Answer: C, D

QUESTION 190:

How often, by default, is a keepalive sent between an IP Phone and its active Call Manager?:

- A. 10 seconds and it can be adjusted in the call manager configuration
- B. 10 seconds and it can not be adjusted
- C. 60 seconds and it can be adjusted in the call manager configuration
- D. 30 seconds and it can be adjusted in the call manager configuration
- E. 60 seconds and it can not be adjusted

Answer: D

QUESTION 191:

Is it possible to disable silence suppression on a per IP phone basis?

- A. Yes, there is a checkbox under the phone configuration.
- B. No, the only configuration is a global one.
- C. Yes, in the device pool configuration for the phones.
- D. No, silence suppression is not necessary for phones.

Answer: B

QUESTION 192:

The IP phone uses:

- A. TCP/IP and UDP/IP to and from the call Manager in order to Tx/Rx stimulus; RTP/UDP/IP to and from the IP phones or H.323 terminals for audio.
- B. UDP/IP to and from the call Manager in order to Tx/Rx stimulus; RTP/IP to and from the IP phones for audio.
- C. TCP/IP to and from the call Manager in order to Tx/Rx stimulus; RTP/UDP/IP to and from the IP phones for audio, video and data.
- D. TCP/IP to and from the call Manager in order to Tx/Rx stimulus; RTP/UDP/IP to and from the IP phones for audio.

Answer: D

QUESTION 193:

Gatekeeper call admission control is a policy-based scheme. What statements

concerning it are true?

- A. It requires static configuration of available resources.
- B. Is not aware of the network topology.
- C. It is not necessary to restrict gatekeeper call admission control schemes to hub-and-spoke topologies.
- D. It is aware of the network topology.

Answer: A, B

QUESTION 194:

What interface does the Cisco CRS Engine use to communicate with Cisco CallManager, regardless of release version?

- A. TAPI (Telephony Application Programming Interface)
- B. CAPI (Common ISDN Application Programming Interface)
- C. JTAPI (Java Telephony Application Programming Interface)
- D. HSSI (High Speed Serial Interface)

Answer: C

QUESTION 195:

When provisioning Cisco CallManager and IPCC Express (CRS), what IPCC Express agent provisioning configurations are possible?

- A. One pool of agents shared among multiple scripts
- B. One pool of CTI ports shared among multiple scripts
- C. NxN mesh of agents and ports shared among N scripts
- D. All of the above

Answer: D

QUESTION 196:

In a Cisco IPCC deployment, an ICM routing client is anything that can generate a route request to the ICM Central Controller. Routing clients include:

- A. Cisco CallManager
- B. Cisco IP-IVR using the CRS platform
- C. PSTN
- D. All of the above

Answer: D

QUESTION 197:

In a Cisco IPCC deployment, the CallManager communicates route requests to the ICM Central Controller via:

- A. A Peripheral Gateway
- B. A voice Gateway
- C. A router
- D. PSTN
- E. None of the above

Answer: A

QUESTION 198:

When deploying multiple Unity-Bridge's what is true?

- A. Each Unity-Bridge requires a dedicated Unity server.
- B. Multiple Unity-Bridges can be connected to one Unity server acting as a "bridge-head."
- C. All Unity-Bridge's must be connected directly to the customers MS Exchange network.
- D. None of the above

Answer: A

QUESTION 199:

Consider phones A and B. Both phones are registered in the same cluster. Phone A is configured with extension 1000. Phone B is configured with extension 2000. Indicate what choice below is necessary and sufficient to allow phone A to be able to call phone B AND phone B to be able to call phone A

- A. Both phone extensions are in the same partition
- B. Both phones are assigned the same Calling Search Space
- C. Both (A) and (B)
- D. None of the above

Answer:

QUESTION 200:

What command enables cRTP?

- A. ip rtp header-compression
- B. ip rtp compress
- C. ip crtp
- D. ip tcp header-compression
- E. ip rtp compress stac

Answer: A

Explanation: A is the correct because it compresses IP/UDP/RTP headers

Not D: Option D compresses IP/TCP/RTP and RTP uses UDP transport protocol

QUESTION 201:

When dimensioning call center agents receive calls from infinite sources (PSTN callers) where calls are queued during the busy hour, the traffic model typically used is:

- A. Extended Erlang-B
- B. Engset
- C. Erlang-C
- D. Binomial
- E. None of the above

Answer:A

QUESTION 202:

Many types of devices can register with a Cisco CallManager Examples are IP phones, voice mail ports, CTI (TAPI/JTAPI) devices, gateways, and DSP resources such as transcoding and conferencing A weight is assigned for each of these devices when provisioning CallManager based upon

- A. The total number of each device type
- B. Memory and CPU resources each device type requires from the server
- C. The number of calls a device handles in the busy hour
- D. All of the above

Answer:

QUESTION 203:

From the perspective of the callManager, the Unity TSP looks and behaves most like a:

- A. H.232 Gateway
- B. CTI Port
- C. Cissco IP Phone
- D. TAPI Device
- E. MGCP Gateway

Answer: D

QUESTION 204:

In Cisco IP Contact Center solution(IPCC), what is in charge of agent state management, selection and reservation?

- A. Voice Gateway
- B. CallManager
- C. ICM Central Controller
- D. None of the above

Answer: C

QUESTION 205:

What command will guarantee a maximum serialization delay of 10 ms on a converged 512 Kbps MLP circuit?

- A. ppp multilink fragment 960
- B. ppp multilink fragment 320
- C. ppp multilink fragment 640
- ppp multilink interleave
- D. ppp multilink fragment-delay 10
- ppp multilink interleave
- E. ppp multilink fragment-delay 10

Answer: D

QUESTION 206:

What is the proper configuration for VoIP authentication via Authentication, Authorization, and Accounting (AAA)?

- A. aaa new-model aaa authentication login default radius
- B. aaa new-model aaa authentication login h225 radius
- C. aaa new-model aaa authentication login h323 radius
- D. aaa new-model aaa authentication login voip radius
- E. aaa new-model aaa authentication h323 login radius

Answer: C

Explanation:

Argument for D: The correct answer is actually either "aaa new-model aaa authentication login h323 radius" or "aaa new-model aaa authentication login voip radius". You can try this on any Cisco router, and both are valid. The location in the command where h323 or voip is, is a free-form text field that you can call anything you like. Another valid command would be "aaa new-model aaa authentication login bubble-gum radius".

QUESTION 207:

A Calling Search Space can be used by CallManager to:

- A. Enable the use of an overlapping dial plan
- B. All of the above
- C. Provide access-list-like security
- D. Restrict calls to numbers such as 1-900 and International long distance calls
- E. Enable the use of E911 services in a Centralized Call Processing model

Answer: B

QUESTION 208:

In order to pass hook-flash on h.323 from FXS to FXO:

- A. connection plar must be configured on the voice-port (FXS)
- B. connection trunk must be configured on the voice-port (FXS) and (FXO)
- C. None of the above
- D. connection plar must be configured on the voice-port (FXS) and (FXO)
- E. connection trunk must be configured on the voice-port (FXS)

Answer: C

QUESTION 209:

A user at Phone A finishes a call. Later, he notes that "CM Fallback Service Operating" is displayed on Phone A. Which are possible explanations for this?

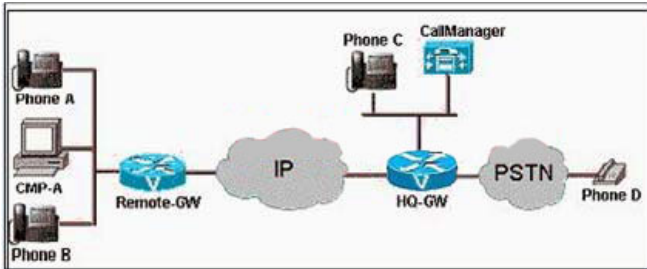

- A. Remote-GW has not received any messages from CallManager within the appropriate timeout period.
- B. The FE on HQ-GW is out of service.
- C. The FXO port on Remote-GW is out of service.
- D. The TCP connection between phone A and call manager has been disrupted.
- E. The FE on Remote-GW is out of service.

Answer: B,D

QUESTION 210:

What standards-based protocol will allow CallManager to seamlessly Integrate with other vendors' traditional PBX systems?

- A. QSIG
- B. All of the above
- C. MGCP
- D. PRI NI-2

Answer: A

QUESTION 211:

Assume that the gateway is a 6608 blade configured as a gateway and running MGCP; Call Manager runs version 3.1, and that a call is made from phone A to phone X. All IP streaming is G.711. Each of the logical links represented carries certain types of traffic. On which links can Skinny (SCCP) traffic be seen?

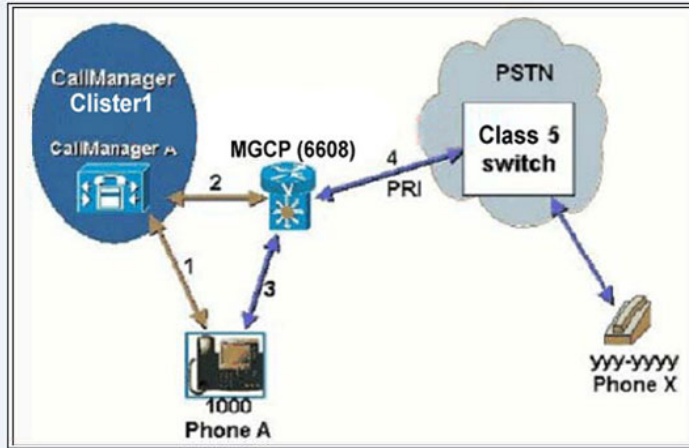

- A. 1, 2, 3, and 4
- B. 1 only
- C. 1 and 4
- D. 2 and 3
- E. 2, 3, and 4

Answer: B

QUESTION 212:

A Cisco SIP Proxy Server can make routing decisions based upon which criteria?

- A. SDP parameters
- B. From: header
- C. User-Portion of the Request-URI
- D. To: header

Answer: C

QUESTION 213:

Which are possible reasons when a user hears echoes of her own voice? (multiple answer)

- A. Mismatch in impedance in the hybrid transformer
- B. ERL is low at the tail circuit
- C. A -3 db loss is taking place in the local loop.
- D. Gain in local loop

Answer: A,B

QUESTION 214:

A Calling Search Space can be used by CallManager to:

- A. Enable the use of an overlapping dial plan
- B. Provide access-list-like security
- C. Enable the use of E911 services in a Centralized Call Processing model
- D. Restrict calls to numbers such as 1-900 and International long distance calls
- E. All of the above

Answer: E

QUESTION 215:

Study the exhibit carefully.

In the figure shown, HSRP is used in conjunction with SRST to preserve telephony functionality in a branch office. Consider a situation where a WAN failure occurs while router A (the primary router) is used. Router A switches to SRST mode to preserve telephony functions. At this point Router A fails, and HSRP backup Router B becomes the active router for the branch office, taking over SRST and routing functions for the office. For Router B to be effective in running SRST for the branch, which types of physical connectivity must be duplicated on Routers A and B?

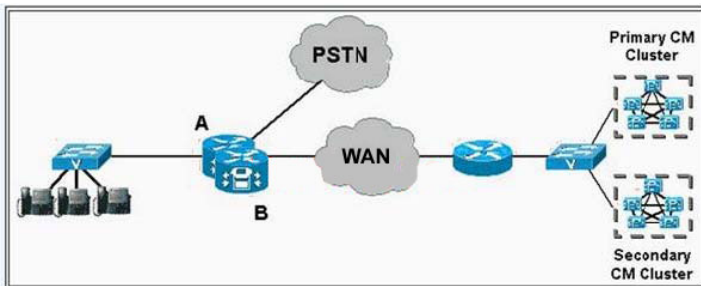

- A. WAN
- B. VLANs
- C. CMs
- D. PSTN
- E. LAN

Answer: D,E

QUESTION 216:

A voice gateway is receiving calls from infinite sources (PSTN callers) during the busy hour where lost calls are cleared (blocked). The traffic model typically used to dimension the number of gateway ports/trunks required is:

- A. Erlang-B
- B. Poisson
- C. B and C
- D. Erlang-C
- E. None of the above

Answer: A

QUESTION 217:

Which standards are related to echo in a network.

- A. 323
- B. 165
- C. 174
- D. 168
- E. 711

Answer: B, D

QUESTION 218:

Assume that the gateway is a 6608 blade configured as a gateway and running MGCP; Call Manager runs version 3.1, and that a call is made from phone A to phone X. All IP streaming is G.711. Each of the logical links represented carries certain types of traffic. On which links can q.921 traffic be seen?

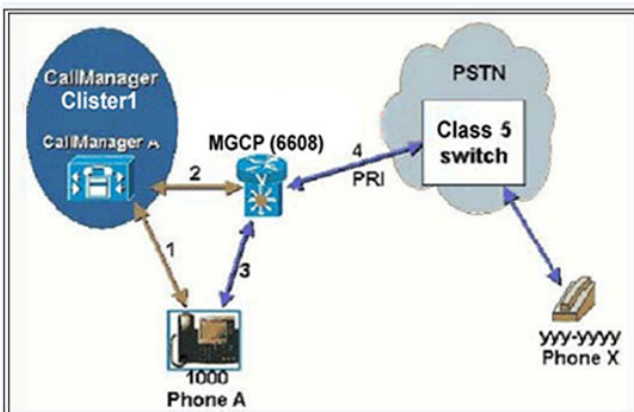

- A. 4 only
- B. 2 and 3
- C. 2 and 4
- D. 1 only
- E. 1, 2, 3, and 4

Answer: A

QUESTION 219:

The maximum device weight capacity a Cisco MCS server can have does NOT depend upon:

- A. The server model and type
- B. CCM software release version
- C. The quantity and the type of phones configured on the cisco MCS server.
- D. The amount of memory, CPU and I/O throughput

Answer: C

QUESTION 220:

What type of signaling provides Dialed Number Information Service (DNIS) on a T1/E1?

- A. Ground start
- B. All of the above
- C. E&M
- D. Loop Start

Answer: B

QUESTION 221:

The user at phone A dials 5551212555. What Digit string is sent to the PSTN for termination assuming call routing is working properly through the IP Network? NOTE: There are 2 exhibits for this question.

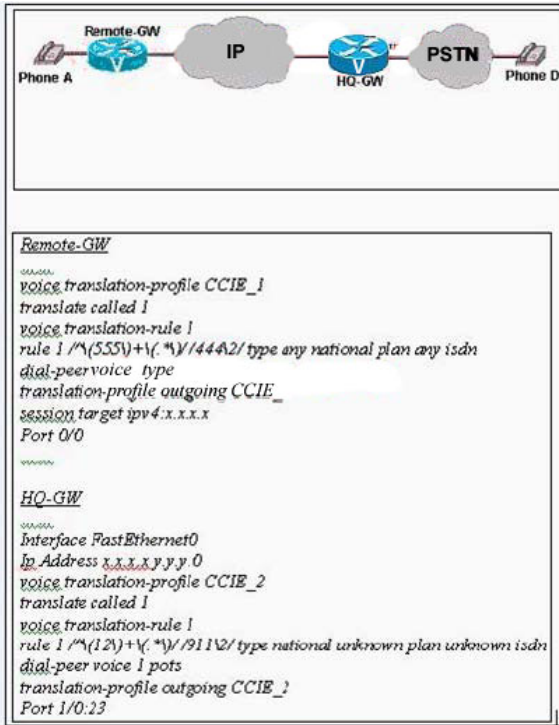

- A. 5551444555
- B. 5551212555
- C. 4441212555
- D. 555911911444
- E. 5554442555

Answer: C

QUESTION 222:

Consider phones A and B. Both phones are registered in the same cluster. Phone A is configured with extension 1000. Phone B is configured with extension 2000. Indicate what choice below is necessary and sufficient to allow phone A to be able to call phone B AND phone B to be able to call phone A.

- A. Both (A) and (B)
- B. Both phones are assigned the same Calling Search Space
- C. None of the above
- D. Both phone extensions are in the same partition

Answer: C

QUESTION 223:

During the busy hour, 100 Erlangs may be generated by:

- A. 2000 calls per hour averaging 3 minutes each
- B. 1 call per hour averaging 100 minutes
- C. None of the above
- D. 3000 calls per hour averaging 2 minutes each
- E. B and C

Answer: E

QUESTION 224:

AAA Can be used for: (multiple answer)

- A. Security
- B. Administration
- C. Admission
- D. Unified messaging
- E. Authentication
- F. Architecture
- G. Billing

Answer: A,E,G

QUESTION 225:

In a remote office in a CM network, which types of call processing functions do SRST preserve?

- A. CTI applications such as IP SoftPhones
- B. IP phone to IP Phone calls
- C. IP Phone to Vmail transcoding services
- D. IP Phone to GW calls
- E. IP Phone to conference DSP resources

Answer: B,D

QUESTION 226:

The terms "Wink start", "Delay start" and "Immediate start" are applicable to:

- A. E1 CAS E&M Signaling

- B. Analog DID Signaling
- C. Analog E&M Signaling
- D. T1 CAS E&M signaling
- E. All of the above

Answer: E

QUESTION 227:

AAA Can be used for: (multiple answer)

- A. Architecture
- B. Billing
- C. Admission
- D. Unified messaging
- E. Authentication
- F. Security
- G. Administration

Answer: B,E,F

QUESTION 228:

PRI is the preferred method for inter-connecting CallManager 3.2 and below to PBX's because:

- A. It is the cheapest solution available
- B. It offers the highest level of inter-operability currently available between CallManager and PBX's
- C. It allows a customer to share their existing Voicemail system with CallManager subscribers whilst delivering full functionality
- D. Caller ID is available

Answer: B,D

QUESTION 229:

An H.323 proxy Gatekeeper Request (GRQ) Registration, Admission, and Status (RAS) message is sent by which endpoints? (multiple answer)

- A. Gateway
- B. Proxy
- C. H.323 Terminal

D. Gatekeeper

Answer: A,C

QUESTION 230:

An AS5300 is configured to authenticate a user for Authentication, Authorization, and Accounting (AAA) RADIUS server by prompting the user for a PIN number, etc., by using application clid_authen_collect. Users are dialing 5551000. What is the correct configuration?

- A. dial-peer voice 1 pots
incoming called-number 555
destination-pattern 1 .
port 0:D
application clid_authen_collect
- B. dial-peer voice 1 pots
destination-pattern 5551
port 0:D
application clid_authen_collect
- C. dial-peer voice 1 pots
destination-pattern 1.
port 0:D
application clid_authen_collect
- D. dial-peer voice 1 pots
incoming called-number 5551000
destination-pattern 1 .
application clid_authen_collect

Answer: A

QUESTION 231:

What does this SMDI packet represent?
MD0010013D 0002914

- A. MWI OFF command for extension 2914
- B. A "Call Forward No Answer" extension 2914 from extension 10013
- C. Extension 2914 calling into voicemail on port 13
- D. A "Forward All Calls", extension 10013 calling 2914
- E. MWI ON command for extension 2914

Answer: C

QUESTION 232:

In CME, which command/debug will show MAC Address, IP Address, DN and Phone Model of phones that are registered/while registering? (Choose 2)

- A. debug ephone detail
- B. show ephone-dn registered
- C. show ephone
- D. debug ephone register
- E. show ephone-dn

Answer: C,D

QUESTION 233:

There are 2 remote sites and one main site. Each site has a CME router with many IP phones in an IPT deployment. The Network Administrator wants to provide all of the phones voicemail access using CUE. Which way can CUE be deployed?

- A. Cisco Unity Express and the CME gateway at each site may NOT be collocated in the same router chassis providing a voicemail access to local IP phones registered to local CME.
- B. One Cisco Unity Express can be used at the main site with CME router providing voicemail access to all the 3 sites.
- C. Cisco Unity Express and the CME gateway at each site must be collocated in the same router chassis providing voicemail access to local IP phones registered to local CME.
- D. One Cisco Unity Express with CME can be used at the main site to provide voicemail access to the IP phones at the main site. Another Cisco Unity Express with CME can be used at one of the remote sites to provide voicemail access for all of the IP phones at the two remote sites.

Answer: C

QUESTION 234:

Refer to the exhibit. While debugging a problem on SIP network, one of the messages displayed when the debug ccsip messages command is entered is shown in the exhibit. What information will the server return to the caller?

```
May 9 02:12:06 370:
Send
  SIP/2.0 415 Unsupported media type
Via: SIP/2.0/UDP 10.0.1.3:54475
From: sip:7300001@10.0.1.3
To: <sip:7900001@10.0.2.3;user=phone>;tag=9B9374-18BE
Date: Tue, 09 May 1993 02:13:06 UTC
Call-ID: 7B8D93F2-6EE5001E-0-9BCB54@10.0.1.3
Server: Cisco VoIP Gateway/ IOS 12.x/ SIP enabled
Content-Type: application/sdp
CSeq: 100 INVITE
Content-Length: 442
```

- A. A list of acceptable formats
- B. An acceptable language code
- C. The acceptable media type
- D. A correct directory number
- E. A list of acceptable media types

Answer: A

QUESTION 235:

Calculate the percentage of overall bandwidth saved (at Layer 3) by cRTP for a G.711 VoIP call packetized at 50 pps.

- A. Approximately 50%
- B. Approximately 60%
- C. Approximately 30%
- D. Approximately 40%
- E. Approximately 20%

Answer: E

QUESTION 236:

Suppose your business has a need to send and receive real-time fax over a VoIP network. Which fax protocol(s) could you implement? (Choose 2)

- A. T.37 Fax Over IP
- B. MGCP
- C. T.38 Fax-relay
- D. Fax Passthrough

Answer: C,D

QUESTION 237:

Which ports must be opened on an IOS firewall to allow successful H.225 RAS (Registration, Admission, and Status) message exchanges between an IOS gatekeeper and IOS H.323 gateways?

- A. UDP 1719 and UDP 1720
- B. TCP 1718 and TCP 1720
- C. UDP 1718 and TCP 1719
- D. UDP 1718 and UDP 1719
- E. TCP 1718 and TCP 1719

Answer: D

QUESTION 238:

Design a two-rate, three-color marker compliant with RFC 2597, RFC 2698 and Cisco best-practices to police Bulk traffic (marked to AF11) to a conforming rate of 5 Mbps and a violating rate of 10 Mbps. Which if the following policy maps meet this criteria?

- A. policy-map BULK-2RATE-3COLOP-MARKER
class BULK
police conform-rate 5000000 violate-rate 10000000
conform-action transmit
exceed-action set-dscp-transmit af12
violate-action set-dscp-transmit af13
- B. policy-map BULK-2RATE-3COLOR-MARKER
class BULK
police cir 5000000 burst 5000000
conform-action transmit
exceed-action set-dscp-transmit af12
violate-action drop
- C. policy-map BULK-2RATE-3 COLOR-MARKER
class BULK
police cir 5000000 pir 10000000
conform-action transmit
exceed-action set-dscp-transmit 12
violate-action set-dscp-transmit 14
- D. policy-map BULK-2RATE-3COLOR-MARKER
class BULK
police cir 5000000 pir 10000000
conform-action set-dscp-transmit 11
exceed-action set-dscp-transmit 12
violate-action set-dscp-transmit 13
- E. policy-map BULK-2RATE-3COLOR-MARKER
class BULK

```
police cir 5000000 be 5000
conform-action set-dsc-transmit af11
exceed-action set-dscp-transmit af12
violate-action set-dscp-transmit af13
```

Answer: C

QUESTION 239:

An IP Phone configured in voice VLAN 128 is registered to a CM cluster. It has speech connection established with another IP Phone which is connected to another CM cluster. Configured codec on both phones is G.711, 20 ms Sample. A PC is connected to back of an IP Phone which is running Sniffer Program and collecting packets coming out of the IP Phone. What would be data frame size coming out of the phone as seen in the Sniffer?

- A. 200 bytes
- B. 218 bytes
- C. 160 bytes
- D. 64 bytes
- E. 128 bytes
- F. 204 bytes

Answer: B

QUESTION 240:

Which method could be used to determine if there is a JTAPI memory leak in a CallManager server?

- A. Check for changes to IP phone settings, like ring settings reverting to default values
- B. Check for an increasing number of fast busys when dialing to the PSTN
- C. Review all CCM User logs
- D. Look at the physical memory available of the server.
- E. Determine if dialing the voice mail pilot number fails to connect to voice mail

Answer: D

QUESTION 241:

Refer to the shown output. Calls to the PSTN are being rejected. Which of the following will correct this issue?

```
Mar 8 09:43:15.383: ISDN Se2/0:23 OSBT: TX >SETUP pd= 8 callref = 0x1B5C
  Bearer Capability i = 0x8090A2
    Standard = CCITT
    TransferCapability = Speech
    Transfer Mode = Circuit
    Transfer Rate = 64 kbit/s
  Channel ID i = 0xA98397
    Exclusive, Channel 23
  Calling Party Number i = 0x2181, '4085552048'
    Plan:ISDN, Type:CallManager
  Called Party Number i = 0x89 '01144123<569999'
    Plan:Private, Type:CallManager
*Mar 8 09:43:15.451: ISDN Se2/0:23 Q931: RX <- RELEASE_COMP pd = 8 callref = 0x9B5C
  Cause i = 0x80BF - Service/option not available, unspecified
```

- A. Change the ISDN Numbering Plan type to International
- B. Add the command 'isdn contiguous-bchan' to the serial interface
- C. Change the channel selection order to ascending
- D. Add the command 'isdn negotiate-bchan' to the serial interface

Answer: A

QUESTION 242:

On authentication, if the login profile matches the login device (that is, the user has a user device profile that is configured for a Cisco IP Phone Model 7960 and logs into a Cisco IP Phone Model 7960), how does Cisco CallManager Extension Mobility behave?
(Choose 2)

- A. The system uses the device profile default for that phone model for phone template and softkey template configuration and, if the phone can support add-on modules, for the add-on module.
- B. If the phone model supports Cisco IP Phone Services and they are configured, the services get copied from the user device profile.
- C. The phone automatically reconfigures with the individual user device profile information
- D. The user can access all of the services that are configured on their device profile.
- E. The system copies all device-independent configurations (that is, user hold audio hold audio source, user locale, userid, speed dials, and directory number configuration except for the setting "line setting for this device") from the user device profile to the login device.

Answer: C,D

QUESTION 243:

Choose which one of these, that is NOT a valid CallManager service parameter:

- A. Cisco Database layer Monitor
- B. Cisco Webdialer
- C. Cisco RTMT Data Collector
- D. Cisco Serviceability Reporter
- E. Cisco Telephony Call Dispatcher
- F. Cisco IP Manager Assistant

Answer: C

QUESTION 244:

When using RSVP to dynamically set up end-to-end QoS across a heterogeneous network there are several QoS Levels that can be configured on the Originating and Terminating Gateway. Which of the following statements correctly describe the difference between these three QoS Levels: Controlled-Load, Guaranteed-delay and Best-effort? (Choose 3)

- A. With Guaranteed-delay QoS Level; if synchronized RSVP is attempted and fails, if acceptable QoS on either gateway is anything other than best effort, the call is released.
- B. With Controlled-load QoS Level; if synchronized RSVP is attempted and fails, the call is released.
- C. With Guaranteed-delay QoS Level; if synchronized RSVP is attempted and fails, if acceptable QoS on the terminating gateway is Controlled-Load or Guaranteed-delay, the call receives best-effort service.
- D. With Controlled-load QoS Level; if synchronized RSVP is attempted and fails, the call receives best-effort service.
- E. With Best-effort QoS Level; no RSVP synchronization is attempted and the call receives best-effort service.

Answer: A,B,E

QUESTION 245:

Refer to the exhibit. Two ports on a 3600 gateway platform are stuck in the EM_PARK state. What workaround can be configured on the router to help alleviate this situation?

```
CertKiller3 # show voice call summary
```

PORT	CODEC	VAD	VTSP	STATE	VPM	STATE
1/0:0.1	-	-	-	-	EM	ONHOOK
1/0:0.2	-	-	-	-	EM	PARK
1/0:0.3	-	-	-	-	EM	PARK
1/0:0.4	-	-	-	-	EM	ONHOOK
1/0:0.5	-	-	-	-	EM	ONHOOK

- A. A call park watchdog timer
- B. Fake Answer
- C. Configure the interface for wink-start signaling
- D. A GetDigit Timeout value

Answer: B

QUESTION 246:

An IP Phone appears to be registered to the Cisco CME system in "show ephone registered". However, it can not make any outgoing calls, nor can it receive any incoming calls. When you pick up the handset or press the speaker button of the IP phone, you do not get a dial tone. Which would be LEAST helpful in solving the problem?

- A. Ensure that the IP Phone is registered to the right CME system by pressing Configuration -> Network Configuration -> TFTP server on the phone
- B. Ensure that the IP Phone shows at least an extension assigned to any buttons
- C. Ensure that a button and ephone-dn association is shown in "show ephone register"
- D. Ensure that the IP Phone is set with the right time/date information
- E. Ensure that the IP Phone is set to use the right CME system as the TFTP server
- F. Ensure that a 'button' command exists to associate a button with a configured ephone-dn in ephone configuration section. Add the 'button' command if needed

Answer: D

QUESTION 247:

To hide its identity when initiating calls, Phone B requests that Server B place its calls for it. What kind of device is Server B?

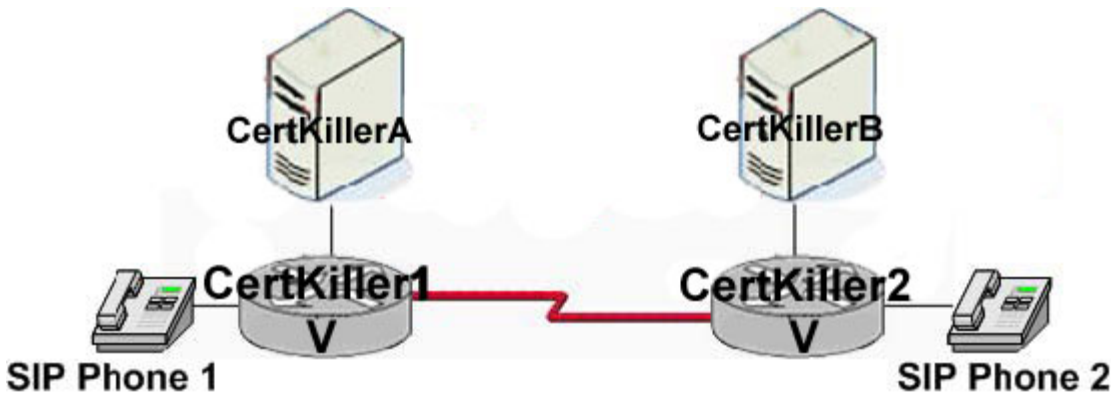

- A. User Agent Client
- B. User Agent Server
- C. Redirect
- D. Registrar
- E. Proxy

Answer: E

QUESTION 248:

A DPA 7630 is being used to integrate a CallManager cluster with an Octel voicemail system. What is configured in the CallManager cluster to establish call paths to the DPA 7630?

- A. A CTI route point is added with a DN for each call path.
- B. A 7902 IP phone is configured for each call path.
- C. A VIP 30 IP phone is configured for each call path.
- D. A voicemail port is added for each call path.
- E. A CTI port is configured for each call path.

Answer: C

QUESTION 249:

In an Intra Cluster Call Flow Trace the following Skinny Call States could be observed. Which of the following is NOT a valid Skinny Call state for an IP Phone?

- A. Off Hook
- B. Call Park
- C. Call Transfer
- D. Call Routing
- E. Connected
- F. Call Waiting

Answer: D

QUESTION 250:

When implementing IP Communicator in CallManager, which two steps need to be accomplished in order for the application to operate correctly? (Choose 2)

- A. Verify CallManager version
- B. Create and associate a user ID with the communicator device
- C. Configure MAC address from Ethernet interface on the PC where IP communicator will be installed in Phone Configuration screen in CallManager
- D. Configure a new CTI port to connect IP Communicator to CallManager
- E. Associate directory number from desk phone with IP Communicator software

Answer: A,C

QUESTION 251:

Which function does CTI Manager provide for a CallManager cluster?

- A. When a Cisco TAPI application fails, the CTI Manager closes the provider and calls at JTAPI ports and route points that have not yet been terminated get redirected to the Call Forward On Failure (CFF) number that has been configured for them.
- B. When a Cisco CallManager node fails, the CTI Manager recovers the affected JTAPI ports and route points.
- C. The CTI Manager and Cisco TSP provide TAPI applications access to CallManager resources and functionality without being aware of a specific CallManager.
- D. The CTI Manager and Cisco TSP provide both TAPI and JTAPI application access to specific CallManager servers in a cluster.

Answer: C

QUESTION 252:

A POTS (PSTN/PBX) user places a call (through Cisco router/gateways) and does not hear a ringback tone before the call is answered. Which of the following actions would probably correct the situation?

- A. Ensure that the terminating gateway has not dropped the Progress Indicator signal
- B. Configure the originating gateway to respond PI=1 to force ringback
- C. Ensure that all intermediate devices carry the correct Progress Indicator without modification
- D. Configure the terminating gateway to send a PI=8 in the Alert message
- E. Configure all intermediate devices to repeat the Progress Indicator signal

Answer: D

QUESTION 253:

Calculate the percentage of overall bandwidth saved (at Layer 3) by cRTP for a G.729 VoIP call packetized at 50 pps.

- A. Approximately 50%
- B. Approximately 40%
- C. Approximately 30%
- D. Approximately 60%
- E. Approximately 20%

Answer: D

QUESTION 254:

In a centralized call processing environment there are three sites, HQ, Site A and Site B that connect over an IP WAN. Each site will use G.711 internally and G.729 between sites. Which two tasks need to be completed to support locations for this solution? (Choose 2)

- A. Two regions will need to be configured for each site, one for the internal codec type and one for the IP WAN codec.
- B. Each site will require a device pool that specifies the site name in the region.
- C. One region will be required for each site.
- D. All sites will become a member of a single region with specific device pools for each site.
- E. Each site will require a region that assigns all devices to a device pool.

Answer: B,C

QUESTION 255:

Which Service Parameter would you select to change the TCP ports used for collecting real-time information within a CallManager cluster?

- A. Cisco Extended Functions service
- B. Cisco Database Layer Monitor service
- C. Cisco CallManager service
- D. Cisco RIS Data Collector service
- E. Cisco Serviceability Reporter service

Answer: D

QUESTION 256:

What is the relationship between a device pool and a region in CallManager configuration?

- A. The device pool sets the default codec for the devices associated with it in a specific region and region sets only the codec that is used between other regions.
- B. Devices use the settings in the region as the default pool for that region.
- C. The device pool sets the intra-region and inter-region codecs and the region makes the association between it and other regions.
- D. Devices acquire a region setting from the device pool to which they are assigned.

Answer: D

QUESTION 257:

Network topology exhibit:

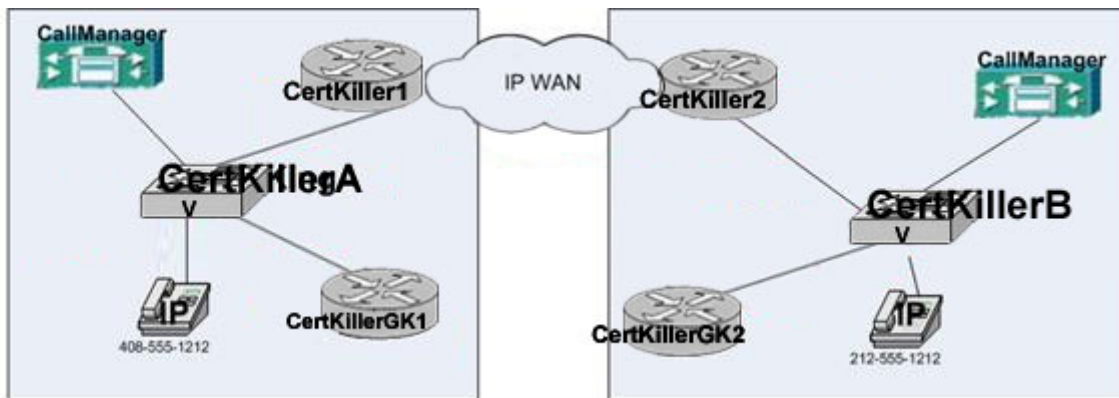

Certkiller GK1 configuration exhibit:

```
CertKillerGK1  
gatekeeper  
zone local CertKillerGK1 certkiller.com 10.1.10.100  
zone remote CertKillerGK2 certkiller.com 10.1.11.100  
zone prefix CertKillerGK1 408.  
zone prefix CertKillerGK2 212  
bandwidth interzone 160  
gw-type-prefix 1#* default-technology  
arq reject-unknown-prefix
```

Certkiller GK2 configuration exhibit:

CertKillerGK2

```
gatekeeper
zone local CertKillerGK2 certkiller.com 10.1.11.100
zone remote CertKillerGK2 certkiller.com 10.1.10.100
zone prefix CertKillerGK2 212.
zone prefix CertKillerGK2 408
bandwidth interzone 160
gw-type-prefix 1#* default-technology
arq reject-unknown-prefix
```

The gatekeeper configurations are shown as entered by the administrator. The gatekeepers are not functioning correctly. What are possible problems? (Choose 2)

- A. The 'gw-type-prefix' commands are incorrect.
- B. The 'zone local' and 'zone remote' commands are incorrect.
- C. The 'zone prefix' commands are incorrect.
- D. The 'bandwidth' commands are incorrect.
- E. The gatekeeper functions have not been activated.

Answer: D,E

QUESTION 258:

Which of the following does NOT describe the Calling Search Space function in CM properly?

- A. Each directory number has CSS.
- B. Calling Search Space is a grouping of partitions to look through when making a call.
- C. CSS defines search for directory numbers in assigned partitions according to dial patterns.
- D. The Calling Search Space defines what numbers are available to a device to call.
- E. The CSS defines Route Patterns and Directory Numbers calls can be received from.

Answer: E

QUESTION 259:

Which statement is TRUE?

- A. If the CM fails any call in progress is dropped.
- B. If the two phones are registered to different CallManagers and either CallManager fails, the call which is made on Inter cluster trunks is torn down.
- C. If two IP phones are registered to the same CallManager, and the CM fails, the active call between those 2 phones goes down.
- D. If a call is made from an IP phone to a gateway (No VG2XX GW considered here), regardless of which CallManager either device is registered to, the call will fail

Answer: B

QUESTION 260:

Which of the following will NOT make a good requirement for hardening an MCS Server's Operating System and its services? (Select 2)

- A. An intrusion protection system: CSA
- B. Harden accounts and passwords
- C. Harden the IP stack by mitigating redirection attacks and enabling SYN flood protection
- D. Keep the OS up to date and install Cisco OS upgrades that can be downloaded from Cisco Connection Online (CCO)
- E. Enable all services including file sharing
- F. Ensure local applications' access to system registry

Answer: E,F

QUESTION 261:

Consider the exhibit. According to the list, please identify all the links between the devices shown where SCCP (Skinny Client Control Protocol) can be used for the two listed devices to communicate. (Please note that the Call Manager version is 4.x or below.)

Please note you MUST identify ALL the links where SCCP can be seen in this diagram.

- Link 1: Cisco 7900 IP Phone to Cisco CallManager
- Link 2: Cisco 3725 Router (populated with an NM-HDV module acting as a DSP FARM) to Cisco CallManager
- Link 3: Cisco ATA 186/188 to Cisco CallManager
- Link 4: Cisco CallManager 1 to Cisco CallManager 2 across an IP Wide Area Network
- Link 5: Cisco Catalyst 6500 populated with a WS-6608-T1 module to Cisco CallManager
- Link 6: Cisco Catalyst 6500 populated with a WS-6624 module to Cisco CallManager 1
- Link 7: Cisco VG248 to Cisco CallManager
- Link 8: Cisco 7960 IP phone located in a remote office to Cisco CallManager 1 (Home Office)

- A. Link 1, Link 5, link 6, Link 8
- B. Link 1, Link 2, Link 3, Link 8
- C. Link 1, Link 2, Link 3, Link 7, Link 8
- D. Link1, Link 2, Link 5, Link 6, Link 7
- E. All Links shown can use SCCP for the devices to communicate.

Answer: C

QUESTION 262:

Which of the following MGCP Commands are not valid? (Select 2)

- A. Make Connection (MKCX)

- B. Notification Request (RQNT)
- C. Delete Connection (DLCX)
- D. Modify Connection (MDCX)
- E. Audit Connection (AUCX)
- F. Reset In Progress (REIP)

Answer: A,F

QUESTION 263:

Given a traffic profile consisting of voice, call signaling, interactive-video, transactional and bulk data, a best-effort class and a "less-than Best Effort" scavenger-class, which class maps would correctly identify these applications? (Note: Assume the applications have already been previously marked to their Cisco QoS Baseline default marking recommendations. Additionally, assume any application classes marked to an RFC 2597 AF PHB may have also been previously remarked by a policer.)

- A. class-map VOICE
match ip dscp 46
class-map INTERACTIVE-VIDEO
match ip dscp 41 42 43
class-map CALL-SIGNALING
match ip dscp 24
class-map TRANSACTIONAL-DATA
match ip dscp 21 22 23
class-map BULK-DATA
match ip dscp 11 12 13
class-map SCAVENGER
match ip dscp 10
- B. class-map VOICE
match ip dscp 46
class-map INTERACTIVE-VIDEO
match ip dscp 30 32 34
class-map CALL-SIGNALING
match ip dscp 24
class-map TRANSACTIONAL-DATA
match ip dscp 20 22 24
class-map BULK-DATA
match ip dscp 10 12 14
class-map SCAVENGER
match ip dscp 8
- C. class-map VOICE
match ip dscp 46
class-map INTERACTIVE-VIDEO
match ip dscp 34 36 38
class-map CALL-SIGNALING

```
match ip dscp 24
class-map TRANSACTIONAL-DATA
match ip dscp 18 20 22
class-map BULK-DATA
match ip dscp 10 12 14
class-map SCAVENGER
match ip dscp 8
D. class-map VOICE
match ip dscp 46
class-map INTERACTIVE-VIDEO
match ip dscp 34 35 36
class-map CALL-SIGNALING
match ip dscp 24
class-map TRANSACTIONAL-DATA
match ip dscp 18 19 20
class-map BULK-DATA
match ip dscp 10 11 12
class-map SCAVENGER
match ip dscp 8
```

Answer: C

QUESTION 264:

If the CFNA and CFB are set to a hunt pilot number, what impact will the maximum hunt timer have on a call sent to the hunt pilot?

- A. The timer limits the number of seconds a call will wait before being forwarded to a voice-messaging system, a specific dialed number, or some personal treatment (if configured), or the call gets released.
- B. The timer limits the number of seconds allotted for hunting through a hunt list.
- C. The timer limits the number of seconds the call will wait for an answer at each member of a line group.
- D. The timer allows limits on the number of seconds allotted to hunting through a line group.

Answer: B

QUESTION 265:

VXML and TCL provide similar services. Which of the following are unique to VXML?
(Choose 2)

- A. Authentication of callers
- B. DTMF digit collection on VoIP dial peers
- C. Support for RTSP servers

- D. Store and Forward of audio streams
- E. Speech recognition and text to speech

Answer: D,E

QUESTION 266:

Which of the following features are supported in Cisco's implementation of RSVP Support for Low Latency Queueing (LLQ)? (Choose 3)

- A. Controlled-Load Network Element Service
- B. Reserve resources for Low Latency and bandwidth guarantees
- C. Guaranteed Quality of Service
- D. LLQ Support on Tunnels

Answer: A,B,C

QUESTION 267:

When configuring IP Manager Assistant (IPMA) in a shared line mode, how are the manager and assistant Directory Numbers (DN) configured?

- A. The manager and assistant share a directory number (DN) and an IP Manager Assistant (IPMA) directory number.
- B. The manager and assistant each have separate directory numbers (DN).
- C. The manager and assistant both share the same directory number (DN).
- D. The manager and assistant have separate directory numbers (DN), but share an IPMA directory number.

Answer: C

QUESTION 268:

An IPCC script is configured with a DB Read to check to see if it is a holiday. Calls to the database fail intermittently. Which trace should be enabled to troubleshoot this issue?

- A. Database Layer Monitor
- B. CTI Manager
- C. SS_DB
- D. RIS Data Collector

Answer: C

QUESTION 269:

ACME is migrating from Exchange 5.5 to Exchange 2000. They have setup an Exchange

Mixed-Mode Environment. Which of the following statements regarding integrating Unity into this environment are correct?

- A. The partner server must be an Exchange 2000 server for Unity to service both Exchange 5.5 and Exchange 2000 mailboxes.
- B. One Unity server partners with an Exchange 2000 server and one Unity server partners with an Exchange 5.5 server. Digital networking is used to forward messages between the systems.
- C. The Unity server can support multiple Exchange 5.5 organizations but only one Exchange 2000 domain.
- D. The Unity server must be voice-mail only until the Exchange migration is complete.

Answer: A

QUESTION 270:

Which 2 functions are performed by a route group?

- A. Performs digit manipulation
- B. Matches dialed number for external calls
- C. Points to the actual gateway/gatekeeper
- D. Chooses path for call routing
- E. Points to prioritized route groups
- F. Points to a route list for routing

Answer: A,C

QUESTION 271:

A CME site has a group of attendants that answer calls for 3 different companies. The dial-plan for the CME site is listed below.

CompanyA: 4085551111

CompanyB: 4085552222

CompanyC: 4085553333

AttendantA: 100

AttendantB: 101

AttendantC: 102

Identify the configuration that will meet the following criteria:

1. Incoming DNIS call to company A, B or C's dial-in number will hunt to the attendant that has been idle the longest.
2. The name of the company that was called should appear on the phone display.
3. Attendants can logout so that calls to Company A, B or C will bypass their phone.

- A. telephony-service
directory entry 1 4085551111 name CompanyA
directory entry 2 4085552222 name CompanyB

directory entry 3 4085553333 name CompanyC
service dnis dir-lookup
ephone-hunt 1 longest-idle
pilot 408555....
list 100,101,102
preference 1
timeout 5

B. telephony-service

directory entry 1 4085551111 name CompanyA
directory entry 2 4085552222 name CompanyB
directory entry 3 4085553333 name CompanyC
service dnis dir-lookup

ephone-dn 1
number 100 secondary 4085551111
preference 1
no huntstop
!

ephone-dn 2
number 101 secondary 4085552222
preference 2
no huntstop
!

ephone-dn 3
number 102 secondary 4085553333
preference 2
no huntstop

C. ephone-dn 1
number 408555....
name CompanyA
preference 1
no huntstop
!

ephone-dn 2
number 408555....
name CompanyB
preference 2
no huntstop
!

ephone-dn 3
name CompanyC
number 408555....
preference 3
no huntstop

D. ephone-dn 1
number 100 secondary 408555....
name CompanyA

```
preference 1
no huntstop
!
ephone-dn 2
number 101 secondary 408555....
name CompanyB
preference 2
no huntstop
!
ephone-dn 3
name CompanyA
number 102 secondary 408555....
preference 2
no huntstop
E. telephony-service
directory entry 1 4085551111 name CompanyA
directory entry 2 4085552222 name CompanyB
directory entry 3 4085553333 name CompanyC
service dnis dir-lookup
ephone-hunt 1 longest-idle
pilot 105 secondary 408555....
list 100,101,102
preference 1
timeout 5
```

Answer: E

QUESTION 272:

Design a three-class policy using MQC tools whenever possible to provision for IPT traffic being carried over a 768 kbps Frame Relay PVC using Cisco recommended best-practice parameters. Which option meets this criteria?

```
A. policy-map WAN-EDGE
class VOICE
priority percent 33
class CALL-SIGNALING
bandwidth percent 5
!
policy-map MQC-FRTS-768
class class-default
shape average 729600 7296 0
compress header ip rtp
service-policy WAN-EDGE
!
interface Serial2/0.12 point-to-point
```

```
frame-relay interface-dlci 102
class FR-MAP-CLASS-768
!
Map-class frame-relay FR-MAP-CLASS-768
Service-policy output MQC-FRTS-768
Frame-relay fragment 640
B. policy-map WAN-EDGE
class VOICE
priority percent 33
compress header ip rtp
class CALL-SIGNALING
bandwidth percent 5
!
Policy-map MQC-FRTS-768
class class-default
shape average 729600 7296 0
fragment frf12 960
service-policy WAN-EDGE
!
Interface Serial2/0.12 point-to-point
Frame-relay interface-dlci 102
class FR-MAP-CLASS-768
C. policy-map WAN-EDGE
class VOICE
priority percent 33
compress header ip rtp
class CALL-SIGNALING
bandwidth percent 5
!
policy-map MQC-FRTS-768
class class-default
shape average 729600 7296 0
service-policy WAN-EDGE
!
interface Serial2/0.12 point-to-point
frame-relay interface-dlci 102
class FR-MAP-CLASS-768
!
map-class frame-relay FR-MAP-CLASS-768
service-policy output MQC-FRTS-768
frame-relay fragment 960
D. policy-map WAN-EDGE
class VOICE
priority percent 70
class CALL-SIGNALING
bandwidth percent 5
```

```
!  
policy-map MQC-FRTS-768  
class class-cefault  
shape average 729600 7296 0  
service-policy WAN-EDGE  
!  
Interface Serial2/0.12 point-to-point  
Frame-relay interface-dlci 102  
Ip rtp header-compression  
Class FR-MAP-CLASS-768  
!  
Map-class frame-relay FR-MAP-CLASS-768  
Service-policy output MQC-FRTS-768  
frame-relay fragment 960  
!
```

Answer: C

QUESTION 273:

A Unity server is being deployed in a dual integration with CallManager and a PBX. The PBX integration will utilize a PBXLink. Which two of the following statements are true? (Choose 2)

- A. The CallManager integration must be completed first.
- B. The PBXLink will communicate with Unity using SMDI.
- C. The PBX and the PBXLink must be co-located.
- D. PCI voice cards are not required for the Unity server.
- E. Each PBXLink port will connect to an analog port in the PBX.

Answer: B,C

QUESTION 274:

Which of the following CallManager 4.1(2) Applications require JTAPI support?

- A. CallBack
- B. ConfList
- C. iDivert
- D. CTI Route Point

Answer: C

QUESTION 275:

Suppose the following command is configured in a gatekeeper: "bandwidth total default

64'. Which statement would be TRUE?

- A. This gatekeeper will not admit any calls because all calls initially account of 128Kbps.
- B. This gatekeeper will admit up to 64 calls, regardless of the codec used.
- C. This gatekeeper will admit a minimum of 4 calls using G.729 codec.
- D. This gatekeeper will admit up to 4 calls using G.729 codec.

Answer: D

QUESTION 276:

Certkiller .com is planning a deployment of Cisco IP Telephony using the Centralized Call Processing model, using Cisco CallManager 4.1(3). The company has 1 HQ and 25 branches interconnected with an MPLS network that provides "full-mesh" connectivity between all sites. Which of the following statements is NOT true?

- A. From the Cisco CallManager's call admission control perspective, a service-provider IP WAN service based on MPLS is in reality equivalent to a hub-and-spoke topology without a hub site.
- B. This configuration requires that call admission control be performed on the central site link independently of the branch links.
- C. This topology implies that, from an IP routing perspective on the enterprise side of the network, each site is one IP hop away from all other sites.
- D. All of the above statements are true.
- E. The Cisco CallManager Servers need to be aware of the underlying MPLS network by setting the appropriate Enterprise Parameters.

Answer: E

QUESTION 277:

What occurs if the system clocks are not synchronized between the sender and receiver of an RTP stream?

- A. When the RTP stream is opened, the sender and receiver synchronize their clocks before the stream commences so that packet sequencing and dejitter will function correctly.
- B. Packets cannot be reordered for sequence and jitter cannot be compensated for.
- C. Packets can be placed in sequence but jitter cannot be compensated for.
- D. Packets may be reordered and jitter may be compensated for as the timestamp is not related to the system time.
- E. Jitter can be compensated for, but packets cannot be reordered if they arrive out of sequence.

Answer: D

QUESTION 278:

Certkiller .com has a headquarters with a centralized CallManager and 5 remote offices. All the remote offices have extensions in the range of 1000-1150. To allow inter-office calls each office has been assigned a 3 digit site code. To call between sites, users will dial an access code followed by the 3 digit site code and the extension. Which of the following describes how these inter-office access codes should be configured?

- A. A route pattern is created for each office and placed in a partition available to phones at that office. The route pattern strips the access code and site code and routes the call to the remote office's gateway.
- B. A translation pattern is created for each office and placed in a partition available to all phones. The translation pattern strips the access code and site code and is assigned a Calling Search Space that includes only the phones located in the office.
- C. A route pattern is created for each office and placed in a partition available to all phones. The route pattern strips the access code and the site code and routes the call to the remote office's gateway.
- D. A translation pattern is created for each office and is placed in a partition available to the phones at that office. The translation pattern strips the access code and site code and is assigned to Calling Search Space that includes all local phones.

Answer: D

QUESTION 279:

Certkiller .com wants to compress the voice data traveling over their WAN connection to their parent company. They are presently using the G.729 loading two voice frames per packet. When they implement cRTP using the ip rtp header-compression command, what will be the bandwidth consumption per call over the HDLC WAN link?

- A. 8.8 kbps
- B. 12.0 kbps
- C. 8.0 kbps
- D. 9.6 kbps
- E. 16.0 kbps

Answer: A

QUESTION 280:

Which would be situations where configuring and using a DNS server would be advisable in an IP telephony network. (Choose 2)

- A. The MTU size in the network is longer than the bandwidth will allow.
- B. If Network Address Translation (NAT) is required for communication between the IP phones and Cisco CallManager.

350-030

- C. The size of the DNS response exceeds 1500 bytes, so only the first 1500 bytes are returned by the DNS server.
- D. DNS names resolution is required within the cluster deployed in a single site.
- E. IP telephony disaster recovery network configurations.
- F. DNS names resolution is required for Multi-Site WAN Deployments with Distributed Call Processing.
- G. DNS names resolution is required for Multi-Site WAN Deployments with Centralized Call Processing.

Answer: B,E

QUESTION 281:

What subsystems must be in service to enable speech recognition for the AA script?
(Choose 2)

- A. ASR
- B. JTAPI
- C. RMCM
- D. Database
- E. TTS

Answer: A,B

QUESTION 282:

Consider the exhibit. The JTAPI Subsystem is showing OUT_OF_SERVICE. From the trace. What is the cause of this issue?

```
%M%NIVR-SS_TEL-4-ModuleRunTimeFailure:Real-time failure in JTAPI subsystem: Module=JTAPI subsystem Failure Cause=7,Failure Module=JTAPI_PROVIDER_INIT, Exception:com.cisco.itapi.PlatformExceptionImpl: Unable to create provider - CCM1.cisco.com %M%NIVR-SS_TEL-7-EXCEPTION:com.cisco.itapi.PlatformExceptionImpl: Unable to create provider - CCM1.cisco.com
```

- A. A referenced CTI Route Point is not associated with the JTAPI user.
- B. There is an error in one of the scripts being loaded.
- C. IPCC is not able to resolve the host name of the CallManager.
- D. The JTAPI user password is not correct.
- E. The CTI Manager service is not running on CallManager.

Answer: C

QUESTION 283:

Two type of RSVP reservation types are:

- A. Distinct and Shared

- B. Reservation and Path
- C. Shared and non-shared
- D. Same and Distinct

Answer: A

QUESTION 284:

Why can't TCP be used for transferring audio and video over UDP? (Choose 5)

- A. Reliable transmission is inappropriate for delay-sensitive data such as real-time audio and video.
- B. TCP does not have a mechanism for sufficiently long buffering and adequate average throughput.
- C. TCP does not contain the necessary timestamp and encoding information needed by the receiving application.
- D. TCP cannot support multicast.
- E. TCP headers are larger than a UDP header.
- F. The TCP congestion control mechanisms decreases the congestion window when packet losses are detected ("slow start").

Answer: A,C,D,E,F

QUESTION 285:

Bob's Bicycles is configuring Unity as an Auto Attendant. The requirements are for outside callers to hear a prompt saying "Press 1 for Sales, Press 2 for Service, Press 3 for News and Events". If they Press 1, they reach a submenu where they are prompted to "Press 1 for Bike Sales, Press 2 for Accessories". If they Press 1, Unity should list the 4 sales people and allow the caller to choose. If they press 2 from the initial prompt they reach a submenu where they are prompted to "Press 1 to schedule an appointment or Press 2 to check the status of your repair". At anytime the caller should be able to press 0 and be transferred to the Operator. What is the minimum number of Call Handlers required?

- A. 7
- B. 11
- C. 9
- D. 8
- E. 10

Answer: D

QUESTION 286:

Match the IP Multicast Components as per their simple definitions.

1. Basic Multicast
2. Reliable Multicast
3. One-to-Many Multicast
4. Inter-Domain Multicast
5. Many-to-Many Multicast
 - a. MBGP , MSDP, Anycast RP, RGMP, BSR
 - b. SSM and IGMP v3
 - c. PIM - Bi-Directional
 - d. PGM
 - e. PIM SM, DM, Auto RP, IGMP v2, CGMP

- A. 1 - e, 2 - d , 3-b, 4-a , 5 - c
B. 1 - a, 2 -b , 3-c , 4-d , 5 - e
C. 1 - e, 2 -c , 3-a, 4-d , 5 - b
D. 1 - d, 2 -b , 3-c, 4-e , 5 - a

Answer: A

QUESTION 287:

Consider the exhibit and configuration. Voice packets are getting marked by another device in the network as DSCP value EF before reaching Router Certkiller 1. Likewise, packets coming from Citrix server are marked as AF41. Naturally, the requirement for voice packets needs to be given the highest priority and citrix packets needs to be given second priority. Which statement about the shown configuration is the most accurate?

CertKiller1 -----ATM-- WAN----- CertKiller2

The following is CertKiller1's config

```
class-map match-all voice
  match dscp EF
class-map match-all citrix
  match dscp AF41
|
policy-map voice-des
  class citrix
    priority 800
  class voice
    priority 500
  class class-default
    fair-queue
|
interface ATM1/0.1 point-to-point
ip address 192.168.1.2 255.255.255.252
pvc 1/50
  vbr-nrt 5000 5000 1
  service-policy output voice-qos
```

A. The configuration is incorrect because you can not have two 'priority' queue within the same policy. You should configure 'citrix' class as CBWFQ using 'bandwidth' since voice packets need to be given the highest priority.

B. The configuration is incorrect because, as per the requirement, voice packets need to be given the highest priority. In the above configuration, 'class citrix' is configured first in the order so it will be given the highest priority. Hence, you should move the 'class voice' up in the order so that 'class citrix' will be pushed down. Thus, voice packets will be given the highest priority.

C. Change the 'class-map' to:

```
Class-map match-any voice_and_citrix
match dscp EF
match dscp AF41
```

And then change the policy to:

```
policy-map voice-qos
class voice_and_citrix
priority 1300
class class-default
fair-queue
```

This change in configuration matches packets with 'EF' first in the order under 'class-map voice_and_citrix' it will get the highest priority.

D. The Change the 'class-map' to:

```
Class-map match-any voice_and_citrix
match dscp EF
match dscp AF41
```

And then change the policy to:

```
policy-map voice-qos
class voice_and_citrix
priority 800
bandwidth 500
class class-default
fair-queue
```

As this change in configuration matches packets with 'EF' first in the order under 'class-map voice_and_citrix' it will get the highest priority in the policy as it matches the priority queue. Packets with AF41 will go into bandwidth queue since it is second in the list.

Answer: A

QUESTION 288:

When comparing SIP, H.323, and MGCP, and SCCP in a VoIP deployment, which Protocol will satisfy the following requirements:

Requirement 1: It has a mechanism for a centralized dial-plan

Requirement 2: The endpoints are considered to be unintelligent

Requirement 3: The protocol must be text-based

- A. H.323
- B. SCCP
- C. MGCP
- D. SIP

Answer: C

QUESTION 289:

When configuring ICD, which of the following must be associated with the JTAPI user?
(Choose 2)

- A. CTI Ports
- B. CTI Route Points
- C. Hunt Pilot
- D. Agent ICD numbers
- E. Agent devices

Answer: A,B

QUESTION 290:

Two divisions in your company need to exchange Unity voice messages using VPIM. Calls from Division A to Division B are made using a site code of "919" followed by the recipient's 4 digit extension. The primary extension in Unity is the user's four digit extension. Which of the following configurations on Division A's Unity server will allow messages to be forwarded between Unity systems using the same seven digit dialing that is used to place direct calls? (Choose 3)

- A. Add the seven digit number as an alternate extension to each VPIM subscriber
- B. Configure the Extension on the VPIM subscriber to "919" plus the recipient's four digit extension
- C. Configure the Remote Mailbox Number on the VPIM subscriber to the recipient's four digit extension
- D. Configure the Dial ID to "919"
- E. Configure the Remote Phone Prefix to "919"

Answer: B,C,D

QUESTION 291:

Network topology exhibit

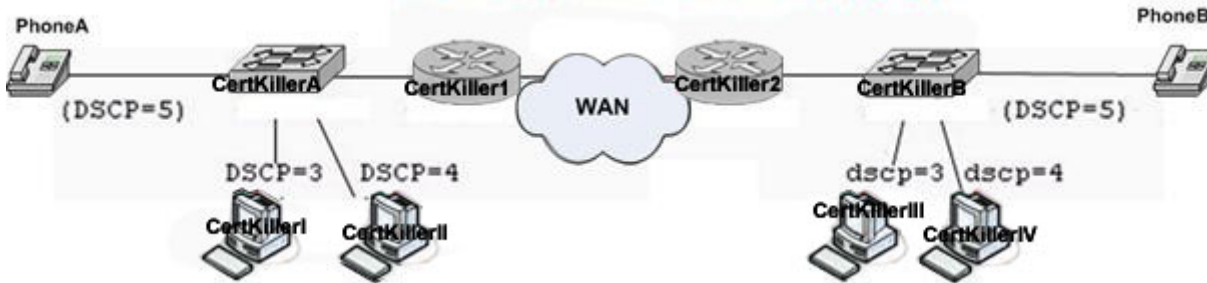

Configuration exhibit.

Configuration of the routers CertKiller1 and CertKiller2

```

class-map match-all voice-qos
  match dscp 3 4 5

policy-map voice-qes
  class voice-qos
    priority 800
  class class-default
    fair-queue

interface ATM1/0.1 point-to-point
  ip address 192.168.1.2 255.255.255.252
  pvc 1/50
  vbr-nrt 5000 5000 1
  service-policy output voice-qos

```

There are customer complaints about voice quality between IP Phones. What could be the potential problem? (Assume that all switchports are configured to trust DSCP and that the WAN link is less than 768 kbps).

- A. None of the other alternatives apply.
- B. It is NOT possible to configure multiple DSCP matches in one statement under 'class-map'. So, the packets that are marked as DSCP=5 by IP phones are not going through priority queue. Instead, it is going through 'default queue'. So, IP phone packets are getting delayed. Thus, it caused the voice quality problem.
- C. It is possible to configure only TWO DSCP matches in one statement under 'class-map'. Due to this invalid config the packets that are marked as DSCP=5 by IP phones are not going through priority queue. Instead, it is going through 'default queue'. So, IP phone packets are getting delayed. Thus, it caused the voice quality problem.
- D. It is possible to configure multiple DSCP matches in one statement under a given class-map. Since the "voice-qos" class is matching three different DSCP values, they are all being assigned to the same "priority" queue, where they are processed in a FIFO manner, which is causing excessive delays on the slow-speed WAN link.

Answer: D

QUESTION 292:

350-030

Consider the exhibit. A call placed from extension 2000 to extension 2001 is forwarded to voicemail and a message is recorded but MWI light is not turned on. From the SMDI trace, what is the most likely cause of this problem?

```
[<CR><LF>MD0010002A5552001<0x20>5552000<0x20><CR><LF><^Y>]
[OP:MWI<0x20>5552001!<EOT>]
[<CR><LF>MD0010004D<0x20>5552001<0x20><CR><LF><^Y>]
[OP:RMV:MWI,0x20>5552001!<EOT>]
```

- A. The 'OutputExternalFormat' parameter is not set correctly.
- B. The 'OutputDnFormat' parameter is not set correctly.
- C. The 'InputDnSignificantDigits' parameter is not set correctly.
- D. The 'External Phone Number Mask' for extension 2001 is not set correctly.

Answer: C

QUESTION 293:

Which of the following is NOT true about Multicast IGMP Snooping?

- A. IGMP snooping requires the LAN switch to examine, or snoop, some Layer 3 information in the IGMP packets sent between the hosts and the router.
- B. When a host in a multicast group sends a IGMP leave message, only that port is deleted from the multicast group.
- C. An IP multicast stream to the IP host can only be stopped by an IGMP Leave message.
- D. When the switch hears the IGMP host report from a host for a particular multicast group, the switch adds the host's port number to the associated multicast table entry.
- E. Because IGMP control messages are transmitted as multicast packets, they are indistinguishable from multicast data at Layer 2.
- F. A switch running IGMP snooping examine every multicast data packet to check whether it contains any pertinent IGMP must control information.

Answer: C

QUESTION 294:

Identify the CallManager Destination Port that gets used with different Protocols as listed below:

- A. Protocol Call Manager Destination Port
- Skinny Gateway (Digital) TCP 2002
- MGCP Control Message UDP 2427
- SCCP TCP 2000

Skinny Gateway (Analogue) TCP 2001
RIS Data Collector TCP 2555
CTI TCP 2748
IPMA Service TCP 2912
B. Protocol Call Manager Destination Port
Skinny Gateway (Digital) TCP 2001
MGCP Control Messages UDP 2427
SCCP TCP 2002
Skinny Gateway (Analogue) TCP 2000
RIS Data Collector TCP 2555
CTI TCP 2748
IPMA Service TCP 2912
C. Protocol Call Manager Destination Port
Skinny Gateway (Digital) TCP 2002
MGCP Control Messages UDP 2912
SCCP TCP 2000
Skinny Gateway (Analogue) TCP 2001
RIS Data Collector TCP 2748
CTI TCP 2555
IPMA Service TCP 2427
D. Protocol Call Manager Destination Port
Skinny Gateway (Digital) TCP 2002
MGCP Control Messages UDP 2748
SCCP TCP 2000
Skinny Gateway (Analogue) TCP 2001
RIS Data Collector TCP 2555
CTI TCP 2427
IPMA Service TCP 2912
E. Protocol Call Manager Destination Port
Skinny Gateway (Digital) TCP 2001
MGCP Control Messages UDP 2427
SCCP TCP 2000
Skinny Gateway (Analogue) TCP 2002
RIS Data Collector TCP 2555
CTI TCP 2912
IPMA Service TCP 2748

Answer: A

QUESTION 295:

In Cisco's Thunderdial and Thundervoice solution using SS7, SLT can terminate which link type?

- A. T1 with IMTs
- B. A-Link only

- C. T1/PRI
- D. F-Link only
- E. A-Link or F-Link
- F. IMTs with Bearer channels

Answer: E

QUESTION 296:

What is the required bandwidth for 3 G.729 VoIP calls on a WAN Frame Relay link with cRTP turned off? (Note: The payload size is 30 bytes.)

- A. 55.8 kbps
- B. 60.9 kbps
- C. 72 kbps
- D. 66 kbps

Answer: B

QUESTION 297:

Design a WAN edge LLQ/CBWFQ policy to accommodate voice, call-signaling, transactional data, bulk data, best effort and a "less than Best Effort" scavenger traffic class. Enable class-based cRTP on the voice class. Enable RFC 2597 congestion avoidance techniques only on application classes assigned an AF PHProvision a "less than Best Effort" queuing policy for scavenger traffic (assume a non-distributed router platform). Also assume that these traffic classes have been correctly classified and marked according to Cisco's best practices. Which option meets this criteria?

- A. policy-map WAN-EDGE-QUEUING
class VOICE
priority percent 33
ip rtp header-compression
class CALL-SIGNALING
bandwidth percent 5
dscp-based random-detect
class TRANSACTIONAL-DATA
bandwidth percent 26
dscp-based random-detect
class BULK-DATA
bandwidth percent 10
dscp-based random-detect
class SCAVENGER
bandwidth percent 1
dscp-based random-detect
class class-default

fair-queue
random-detect dscp-based
B. policy-map WAN-EDGE-QUEUING
class VOICE
priority percent 33
ip rtp header-compression
class CALL-SIGNALING
bandwidth percent 5
dscp-based random-detect
class TRANSACTIONAL-DATA
bandwidth percent 26
dscp-based random-detect
class BULK-DATA
bandwidth percent 10
dscp-based random-detect
class SCAVENGER
bandwidth percent 1
class class-default
fair-queue
C. policy-map WAN-EDGE-QUEUING
class VOICE
priority percent 33
ip rtp header-compression
class CALL-SIGNALING
bandwidth percent 5
random-detect dscp-based
class TRANSACTIONAL-DATA
bandwidth percent 26
random-detect dscp-based
class BULK-DATA
bandwidth percent 10
random-detect dscp-based
class SCAVENGER
bandwidth percent 1
class class-default
faor-queue
random-detect, dscp-based
D. policy-map WAN-EDGE-QUEUING
class VOICE
priority percent 33
compression header ip rtp
class CALL-SIGNALING
bandwidth percent 5
class TRANSACTIONAL-DATA
bandwidth percent 26
random-detect dscp-based

```
class BULK-DATA
bandwidth percent 10
random-detect dscp-based
class SCAVENGER
bandwidth percent 1
class class-default
bandwidth percent 25
```

Answer: D

QUESTION 298:

A software media termination point should be deployed to support which call processing models and services?

- A. To support remote sites in a centralized call processing model and H.323v1.
- B. To support IP Telephony Service Providers and H.323v1.
- C. To support remote sites for multi-site distributed call processing models and H.323v1.
- D. To support single site call processing models and H.323v1.

Answer: D

QUESTION 299:

Which 3 functions are NOT performed by a Route Pattern? (Choose 3)

- A. Chooses path for call routing
- B. Performs digit manipulation
- C. Points to a route list for routing
- D. Matches dialed number for external calls
- E. Points to the actual IP phone
- F. Points to prioritized route groups

Answer: A,E,F

QUESTION 300:

Which of the following are mandatory sub-commands under call-manager-fallback and will help an IP Phone register to an IOS router in SRST mode? (Choose 3)

- A. max-dn
- B. access-code
- C. keepalive
- D. max-ephones
- E. dialplan-pattern
- F. ip source-address

Answer: A,D,F

QUESTION 301:

Which of the following are NOT true statements about Certificate Trust List (CTL) File?
(Choose 2)

- A. Phones need to trust all entries in the CTL file which could be CCM, TFTP, CAPF, etc.
- B. The CTL is created by CTL Client on administrator workstation.
- C. It is a list of devices and credentials that a phone should trust on the network.
- D. The CTL file is signed by administrator workstation password.
- E. The CTL file is loaded to the phone each time when authentication is required.
- F. It contains identity, public key and role information.

Answer: D,E

QUESTION 302:

Consider the exhibit. Based on the configuration shown, what digit pattern will the Voicemail server see if there is no answer when IP phone B is called from phone A?
(Note: Assume that the CallManager Servers have become unreachable, and therefore the IP Phones are in SRST mode and have registered to the Gateway with the shown configuration.)

IP Phone A Ext 1000	1000 calls 2000 ----->	IP Phone B Ext 2000	1000 is forwarded ----->	Voicemail Server Ext 3000
------------------------	---------------------------	------------------------	-----------------------------	------------------------------

Configuration

```
call-manager-fallback
voicemail 3000
call-forward busy 3000
call-forward noan 3000 timeout 3

vm-integration
pattern direct 2 CGN *
pattern ext-to-ext no-answer 5 FDN * CGN *
pattern ext-to-ext busy 7 FDN * CGN *
pattern trunk-to-ext no-answer 4 FDN * CGN *
pattern trunk-to-ext busy 6 FDN * CGN *
```

- A. 72000*1000*
- B. 21000*
- C. 52000*1000*
- D. 62000*1000*
- E. 42000*1000*

Answer: C

QUESTION 303:

Refer to the exhibit. While testing a new Cisco CallManager integration it is determined that IP phones can place and receive calls from PBX phones but cannot place calls to the PSTN. What are possible causes of this problem? (Choose 2)

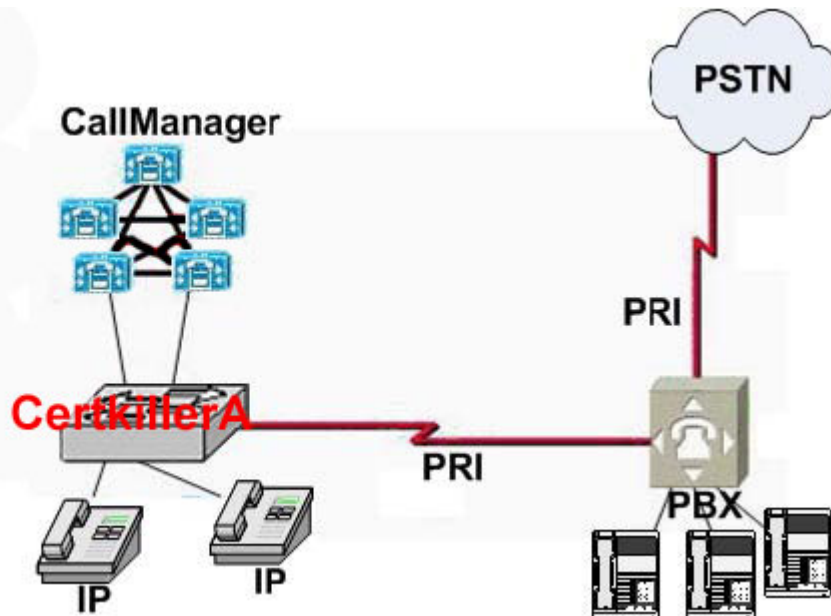

- A. The CallManager is not sending the correct digits to the PBX.
- B. The gateway's CSS does not contain the partition assigned to the IP phones.
- C. The IP phones' CSS does not contain the partition assigned to the PBX users.
- D. The PBX is restricting trunk to trunk transfers.
- E. The T1 to the PBX is using a different ISDN protocol than the T1 to the PSTN.

Answer: A,D

QUESTION 304:

Certkiller .com. is planning a deployment of Cisco IP Telephony using the Centralized Call Processing model. The company has 1 HQ and 25 branches in a hub and spoke configuration. The company wants to offer the option to use Cisco IP Communicator to some of its employees that are often on the road. Which of the following statements is not true?

- A. The IT department will need to verify that the employees' laptop technical characteristics satisfy the Cisco IP Communicator's minimum requirements.
- B. It is recommended that all users be requested to accept Certkiller .com note stating that 911 calls will not work properly due to the mobility nature of the Cisco IP

350-030

Communicator.

C. The administrator will need to load-balance the load across the various CTI Managers in the cluster.

D. It is recommended that a new region be created for all the Cisco IP Communicators, where a low-bandwidth codec such as g.729 be used at all times.

Answer: C

QUESTION 305:

Which of the following statements is FALSE about Cisco Discovery Protocol (CDP)? (Choose 3)

A. The platform TLV (TLV type 0x0006) contains an ASCII character string that describes the hardware platform of the device.

B. It uses a broadcast packet with the destination MAC address of 01-00-CC-CC-CC

C. It uses a multicast packet with destination MAC address of 01-00-CC-CC-CC.

D. It is an excellent tool for displaying interface status on switches.

E. Use cdp timer command to change update times; default is 60 seconds

F. It works on top of the network layer and data link level.

Answer: B,C,F

QUESTION 306:

Consider the exhibit. A site has configured a CTI Route Point to forward calls to extension 5900 to Unity for Call Handler Greeting Administration. When an administrator calls extension 5900 they hear the Opening Greeting instead of the CUGA. What is the probable cause?

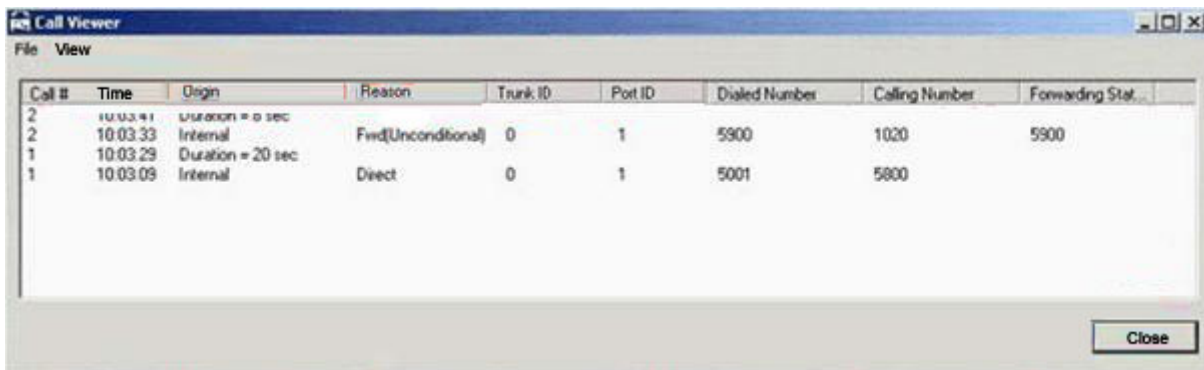

The screenshot shows a 'Call Viewer' window with a table of call records. The table has columns for Call #, Time, Origin, Reason, Trunk ID, Port ID, Dialed Number, Calling Number, and Forwarding Stat. The data rows are as follows:

Call #	Time	Origin	Reason	Trunk ID	Port ID	Dialed Number	Calling Number	Forwarding Stat.
2	10:03:33	Internal	Fwd(Unconditional)	0	1	5900	1020	5900
1	10:03:29	Internal	Direct	0	1	5001	5800	

A. Extension 5900 has not been defined in Unity.

B. The Voice Mail Box Mask in CallManager is set to 1020 instead of XXXX.

C. A greeting has not been recorded for mailbox 5900.

D. The call routing rule is not configured correctly.

Answer: D

QUESTION 307:

Consider the exhibit. A call placed from extension 2000 to extension 2001 is forwarded to voicemail. Instead of the greeting for 2001, the default greeting is heard. The caller is able to select extension 2001 from the voicemail AA and leave a message. From the SMDI trace, what is the most likely cause of this problem?

```
[<CR><LF>MD0010002A5552001<0x20>5552000<0x20><CR><LF><^Y>]  
[OP:MWI<0x20>2001!<EOT>]  
[<CR><LF>MD0010004D<0x20>2001<0x20><CR><LF><^Y>]  
[OP:RMV:MWI,0x20>2001!<EOT>]
```

- A. The LTN does not match the port the call is forwarded on.
- B. The 'InputDnSignificantDigits' parameter is not set correctly.
- C. The 'External Phone Number Mask' for extension 2001 is not set correctly.
- D. The 'OutputDnFormat' parameter is not set correctly.
- E. The 'OutputExternalFormat' parameter is not set correctly.

Answer: A

QUESTION 308:

Which of the following statements outline the correct way to implement a non-standard softkey template?

- A. Select the default softkey template, rename it; insert it; modify it and update the changes.
- B. Select a softkey template; copy the template and rename it; insert it; modify the template and update the changes.
- C. Select a softkey template; rename it; modify it and update the changes.
- D. Select add softkey template, name it; update it; modify the template and update the changes.

Answer: B

QUESTION 309:

Which of the following are H.245 standard functions? (Choose 2)

- A. H.225 UDP port call setup negotiations between calling and called party
- B. IP address exchange and UDP port negotiations between calling and called party
- C. IP port negotiations between calling and called party
- D. CODEC negotiations between calling and called party
- E. IP phone on-hook and off-hook signal exchange

Answer: B,D

QUESTION 310:

Which of the following steps will not fit into Extension Mobility(EM) service login or logout flow on Cisco CallManager 4.X and IP Phones ? (Choose 2)

- A. Extension Mobility IP Phone Service URL is created for both Extension Mobility login and for Extension Mobility logout.
- B. If EM user has more than one device profile associated with him, he is prompted to select the profile he wants to log in with.
- C. The EM user is associated with one of the device profiles.
- D. A device profile needs to be created and assigned with Extension Mobility user in the CallManager
- E. The EM user selects the EM Service on the IP phone.
- F. The EM user's profile is loaded on the phone without the phone breaking its TCP connection with CallManager.

Answer: A,F

QUESTION 311:

An IP phone is connected to a Cisco inline power switch Port. Switch is running IOS image on it. The switch port is acting as a trunk and is running both Voice and Data VLAN configuration on it. We would like the IP Phone connected to switch port in voice VLAN to set layer 2 priority of all the packets coming from PC to default 0. Which IOS CLI in Interface Port configuration on Inline power switch can help us achieve our objective?

- A. switchport access priority extend cos 0
- B. switchport mode access priority extend cos 0
- C. switchport access extend cos 0
- D. mls qos priority extend cos 0
- E. switchport priority extend cos 0
- F. switchport trunk priority cos 0

Answer: E

QUESTION 312:

Certkiller .com is planning a deployment of Cisco IP Telephony using the Centralized Call Processing model. The company has 1 HQ and 25 branches in a hub and spoke configuration. In the design phase, they are wondering if they will need to implement Software or Hardware Media Termination Points (MTP) in their networks. Which of these functions are related to Hardware MTPs?

- A. Bridge two connections that utilize different packetization periods (different packet sizes).
- B. They are suited for multi-site deployments, where transcoding is not required.
- C. All low bit-rate (LBR) calls must be transcoded prior to joining the conference call
- D. Transcoding from A-Law to Mu-Law.
- E. RFC2833 Support for SIP Trunks.

Answer: A,D,E

QUESTION 313:

Identify the correct sequence of events, as seen in the sniffer traces, that takes place when an IP Phone is initially registering to the Call Manager.

- A. - Download SEP(MAC).cnf file from TFTP server
 - Send StationAlarm Skinny Protocol message to CallManager
 - Send StationRegister Skinny Protocol message to CallManager
 - Download Phone button template and softkeys from CallManager.
 - Download locale files from TFTP server
- B. - Download locale files from TFTP server
 - Download SEP(MAC).cnf file from TFTP server
 - Send StationRegister Skinny Protocol message to CallManager
 - Send StationAlarm Skinny Protocol message to CallManager
 - Download Phone button template and softkeys from CallManager
- C. - Download SEP(MAC).cnf file from TFTP server
 - Download locale files from TFTP server
 - Download Phone button template and softkeys from CallManager.
 - Send StationAlarm Skinny Protocol message to CallManager
 - Send StationRegister Skinny Protocol message to CallManager
- D. - Download locale files from TFTP server
 - Download SEP(MAC).cnf file from TFTP server
 - Send StationAlarm Skinny Protocol message to CallManager
 - Send StationRegister Skinny Protocol message to CallManager
 - Download Phone button template and softkeys from CallManager
- E. - Download SEP(MAC).cnf file from TFTP server
 - Download locale files from TFTP server
 - Send StationAlarm Skinny Protocol message to CallManager
 - Send StationRegister Skinny Protocol message to CallManager

- Download Phone button template and softkeys from CallManager

Answer: E

QUESTION 314:

Which of the following does not accurately describe the database layer service in CM?

- A. The publisher maintains a TCP connection with each subscriber database. For real-time processing and call processing, each CallManager maintains a TCP connection with every other CallManager via the Intra Cluster Communications Signalling (ICCS) protocol.
- B. The database layer is a set of DLLs that provide a common access point for data insertion, retrieval, and modification of the database.
- C. The database layer monitors access to the Publisher. During a failure, it will try a replicated database for device information and monitor the publisher for its return.
- D. The database information itself is made up of one publisher database, which is the very 1st CallManager Machine in the CM cluster. All remaining machines in a cluster are subscriber databases.
- E. All database records including Call Detail Records (CDR) are replicated from publisher to subscriber.

Answer: E

QUESTION 315:

Given a Catalyst 3550 configured to support IPT, which configuration would correctly identify voice and call signaling traffic originating from a Cisco IP Phone? (Note: Assume that all other QoS configurations - both on the switch and on the Cisco CallManager - are set according to current Cisco best-practice recommendations.)

- A. class-map match-all VOICE
match ip dscp 46
class-map match-all CALL-SIGNALING
match ip dscp 24
- B. class-map match-all VOICE
match cos 5
class-map match-all CALL-SIGNALING
match cos 3
- C. class-map match-all VOICE
match dscp 5
class-map match-all CALL-SIGNALING
match dscp 3
- D. class-map match-all VOICE
match dscp ef
class-map match-all CALL-SIGNALING

match dscp af31

Answer: A

QUESTION 316:

IP phones A (extension 1001), B (extension 1002), and C (extension 1003) are registered to the CME system and are able to call each other by dialing each others' extension numbers. However, when any of the phones attempt to transfer a call to any of the other phones they get a fast busy tone. How can the transfer issue be resolved? (Choose 2)

- A. Reset the phones so that the transfer capability will work.
- B. Add this command under "telephony service" on the CME system: transfer-pattern 1 . . . or transfer-pattern . . . '
- C. Add this command under "telephony-service" on the CME system: transfer-system full-consult
- D. Upgrade the IP phone firmware with the latest version.

Answer: A,B

QUESTION 317:

Consider the Exhibit. Certkiller .com has added two remote sites (Site 2 and Site 3) with a Cisco CME running per each site. Each remote site has got its own voicemail solution using CUE(see site 2 for details), however, Site2 needs to be integrated with the Cisco CallManager deployed in headquarters to allow calls between CCM phones 3xxx at Headquarters and CME at remote sites (1xxx and 2xxx). Regarding CCM Integration with the CME system in Site 2: Site 2's phones still can not call phones in Headquarters. When 1001 calls 3001, 1001 hears ring tones, but gets disconnected after a few rings, or when 3001 is picked up to answer. Which of the following actions should be taken? (Choose 3)

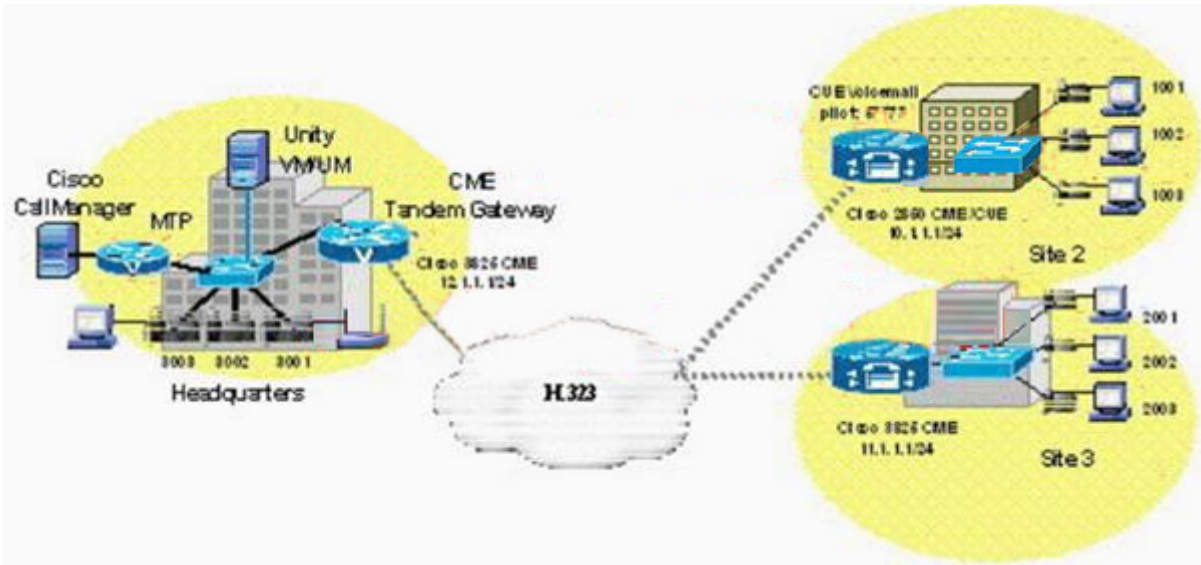

- A. On CCM, turn Media Termination Point (MTP) off
- B. Add a Transcoder on CME in Site 2 or in the network to convert to the right codec before transmission the media
- C. Check if there is a codec mismatch by either forcing the dial-peer on CME in site 2 to use G.711 or configured the CCM in Headquarters to support G.729 for WAN and G.711 for local
- D. On CCM, turn Media Termination Point (MTP) on

Answer: B,C,D

QUESTION 318:

You have a CallManager with a software conference bridge. When users try to use the conference bridge they get the error "No conference bridges available". Which of the solutions will resolve this issue?

- A. The IP voice media streaming application needs to be started on the CallManager for the conference bridge to register.
- B. The DSP conference resources on the IP gateway are improperly configured and will need to be deleted and reconfigured.
- C. The CallManager needs to be stopped and restarted for the conference bridge to register.
- D. The software conference bridge requires external DSP resources to be configured for this service to operate correctly.

Answer: A

QUESTION 319:

Which of the following is a possible cause of the JTAPI Subsystem to be in

PARTIAL_SERVICE?

- A. There is an error in one of the scripts being loaded.
- B. The CTI Manager service is not running on CallManager.
- C. A referenced CTI Route Point is not associated with the JTAPI user.
- D. The JTAPI user password is not correct.
- E. IPCC is not able to resolve the host name of the CallManager.

Answer: C

QUESTION 320:

Certkiller .com. is planning a deployment of Cisco IP Telephony using the Centralized Call Processing model. The company has 1 HQ and 25 branches in a hub and spoke configuration. Additionally, there will be an interconnection with multiple Telephony Service Providers using H323. Which Call Admission Control methods should be used in this network?

- A. Use GK-based CAC with the Telephony Service Providers and with the branches
- B. Use Locations-based CAC with the branches and GK-based CAC with the Telephony Service Providers
- C. Use Locations-based CAC with the Telephony Service Providers and with the branches
- D. Use Locations-based CAC with the Telephony Service Providers and GK-based CAC with the branches

Answer: B

QUESTION 321:

Consider the exhibit. On which two of the links (labeled A through F) would SCCP be used as the protocol? (Choose 2)

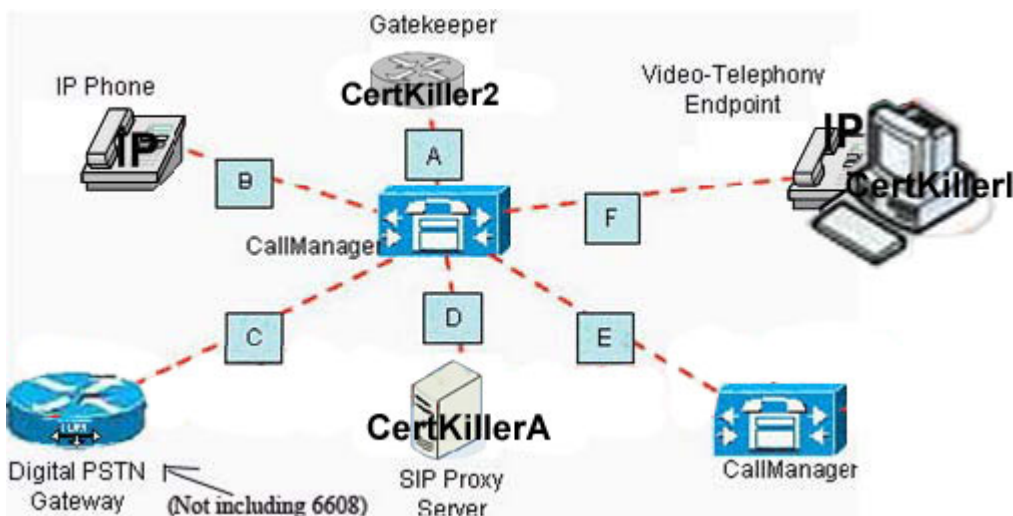

- A. A
- B. B
- C. C
- D. D
- E. E
- F. F

Answer: B, F

QUESTION 322:

Based upon your understanding of an SCCP 7960 IP phone bootup sequence, what must be true for the CallManager to send the IP phone an SEPDefault.cnf file instead of an SEP (mac address) file? (Choose 3)

- A. The IP phone must be configured in the "default" partition.
- B. The IP phone should not have previously registered with this CallManager cluster.
- C. Auto Registration must be enabled.
- D. The IP phone must request SEPDefault.cnf file explicitly.
- E. The IP phone must have previously registered, but the IP Phone was power cycled.

Answer: B,C,D

QUESTION 323:

Users are complaining that the music on hold marketing files for this month is not being played when users are placed on hold. Which of the following are issues that need to be investigated? (Choose 3)

- A. Ensure the IP voice media streaming application has been stopped and restarted
- B. Ensure a new directory has been created for the new media files
- C. Ensure the new music files are in the correct format to be used with CallManager
- D. Ensure the users have selected the correct MoH files for customer calls
- E. Ensure the location of the new music files is what the MoH server expects

Answer: A,C,E

QUESTION 324:

You have two locations with CallManagers, Tampa and Atlanta. Both locations initiate video conferences. In each CallManager there are media resource groups:

TPAHardware: HW-CONF1, VC-CONF1, XCODE1

TPASoftware: MTP1, MOH1, SW-CONF1

ATLHardware: HW-CONF2, VC-CONF2, XCODE2

ATLSoftware: MTP2, MOH2, SW-CONF2

How should the Media Resource Group Lists be configured in the two locations so that video conferencing resources would be applied to video conferences?

- A. In Tampa use the ATLHardware as primary and TPASoftware as secondary for video conferencing resources.
- B. In Tampa and Atlanta use the TPAHardware MRG as the source for video conferencing resources.
- C. In Tampa and Atlanta use the local hardware resources as primary and the other sites hardware resources as secondary conferencing resources.
- D. In Atlanta use the ATLHardware as primary and ATLSoftware as secondary for video conferencing resources
- E. In Tampa use the TPAHardware as primary and ATLHardware as secondary for video conferencing resources.

Answer: C

QUESTION 325:

For a phone call going out of Call Manager on SIP trunks to SIP endpoints in CM 4.X version, MTP is required for call termination and for becoming RFC 2833 compliant. Which of the following is Not a correct explanation for using MTP for this call?

- A. RFC 2833 defines a dynamic payload type for DTMF tones.
- B. This payload type is configurable in Service Parameter as "SIPDefaultTelephonyEventPayloadType". Default value as 101.
- C. Standard for SIP DTMF is based on RFC2833 which uses in-band payload types to indicate tones.
- D. This payload type is fixed and not negotiated between CallManager and SIP endpoints via the SIP messages and is passed to MTP during media establishment.
- E. By making SIP calls use MTP, DTMF relay between in-band and out-of-band digits are accomplished.

Answer: D

QUESTION 326:

Which of the following does NOT accurately describe the Partitions function in CM?

- A. CSS are assigned to Partitions.
- B. Partition is a logical grouping of Directory Numbers and Route Patterns with similar reachability characteristics.
- C. A directory number may appear in more than one partition.
- D. When a DN or Route Pattern is placed into a certain partition, this creates a rule for who can call that device or Route List.
- E. Each directory number has CSS.

Answer: A

QUESTION 327:

Which port(s) must be opened on an IOS firewall to allow successful MGCP (Media Gateway Control Protocol) message exchanges between a CallManager and an IOS MGCP PRI gateway?

- A. UDP 2427 and UDP 2428
- B. TCP 2000 and TCP 2002
- C. TCP 2427 and UDP 2428
- D. UDP 2427 and TCP 2428
- E. UDP 2427

Answer: D

QUESTION 328:

Which three statements describe best practices when implementing Unity Unified Messaging in an Exchange 2000 environment? (Choose 3)

- A. A Unity server can service remote mailboxes if they are in the same Exchange 2000 Routing Group as the partner Exchange server.
- B. Unity should be installed in the same Windows 2000 site as the Exchange servers.
- C. A Unity server should service a single Exchange Administrative Group.
- D. Unity should use the same Domain Controller as the Exchange servers.
- E. Each Unity server should have its own partner Exchange server.

Answer: B,C,D

QUESTION 329:

Consider the exhibit. A site is using 5 digit extensions for internal calling. The voicemail pilot number is 40000. Calls to extension 75000 hear the Unity Opening Greeting instead of the subscriber's greeting when forwarded to Unity. What is the probable cause?

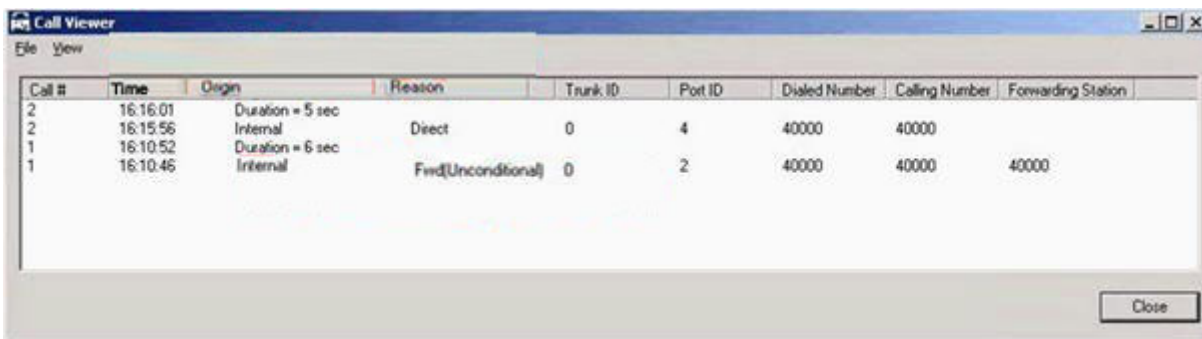

The screenshot shows a 'Call Viewer' window with a table of call records. The table has columns for Call #, Time, Origin, Reason, Trunk ID, Port ID, Dialed Number, Calling Number, and Forwarding Station. The data rows are as follows:

Call #	Time	Origin	Reason	Trunk ID	Port ID	Dialed Number	Calling Number	Forwarding Station
2	16:16:01	Duration = 5 sec						
2	16:15:56	Internal	Direct	0	4	40000	40000	
1	16:10:52	Duration = 6 sec						
1	16:10:46	Internal	Fwd(Unconditional)	0	2	40000	40000	40000

- A. The Voice Mail Box Mask in CallManager is set to 40000 instead of XXXXX.
- B. A greeting has not been recorded for mailbox 75000.
- C. Extension 75000 has not been defined in Unity.
- D. The call CUGA routing rule Attempt Forward to Greeting does not exist.

Answer: A

QUESTION 330:

In a CallManager 4.x server, if the clocks on both systems need to be synchronized, which of the following commands will accomplish this task?

- A. timeset
- B. ntpdate
- C. ntpset
- D. only ntp
- E. ntpclock

Answer: B

QUESTION 331:

Which of the following best describes how MWI is accomplished when integrating Unity with multiple CallManager Express systems?

- A. One CallManager Express system is configured as a CallManager in the Unity server and relays MWI messages to the other CallManager Express systems using SCCP.
- B. One CallManager Express system is configured as a SIP MWI server and relays MWI messages to the other CallManager Express systems.
- C. Each CallManager Express system is defined as a CallManager cluster in the Unity server. The Unity server sends MWI to the appropriate CallManager Express systems based on the cluster definition.
- D. The Unity server sends MWI to all CallManager Express systems. The appropriate CallManager Express system processes the MWI and the other CallManager Express systems discard the MWI.

Answer: B

QUESTION 332:

What is the purpose of CAC on a converged network?

- A. To ensure that a new voice call does not degrade existing data flows on a time division multiplexed circuit.
- B. To ensure that a new voice call does not degrade existing voice calls on a statistically

multiplexed circuit.

C. To ensure that a new voice call does not degrade existing data flows on a statistically multiplexed circuit.

D. To ensure that a new voice call does not degrade existing voice calls on a time division multiplexed circuit.

Answer: B

QUESTION 333:

What is the required bandwidth for 3 G.711 VoIP calls on an Ethernet link? (Note the packet per seconds count is set to 33 pps.)

A. 192 kbps

B. 238.5 kbps

C. 223.8 kbps

D. 240 kbps

Answer: B

QUESTION 334:

Which of the following are the minimum requirements to have signaling encryption between CM and gateway, as well as SRTP between gateway and IP phones? (Choose 3)

A. IPSEC tunneling in Windows 2000 of CallManager server

B. IOS router configured in MGCP

C. CallManager 4.1 with CTL installed

D. IOS router configured in H323

E. Router with NM-HDV module

Answer: A,B,C

QUESTION 335:

A CallManager Group can provide which two features to your call processing system? (Choose 2)

A. Support for redundancy by enabling you to designate a primary and backup Cisco CallManagers for each group

B. Enables you to distribute voice mail support across multiple Unity servers

C. Enables you to distribute the control of devices across multiple Cisco CallManagers

D. Support for control of IPMA across primary and backup Cisco CallManagers for each group

E. Support for SRST in remote offices

Answer: A,C

QUESTION 336:

Which two of the following require specific Active Directory schema extensions?
(Choose 2)

- A. Unity AMIS Networking
- B. Unity SMTP Networking
- C. Unity Bridge Networking
- D. Unity VPIM Networking

Answer: C,D

QUESTION 337:

Which type of media resources would be required for a single site call processing model?

- A. Locations
- B. Regions
- C. Transcoders
- D. MTP

Answer: D

QUESTION 338:

Calls to an ICD queue should reserve an available agent and connect the call after a database lookup is performed. How should the script be configured to accomplish this?

- A. Set the Resource Step Connect option to No and perform a Connect after the database lookup is completed.
- B. Issue a Call Hold after the Resource Step selects an agent and release the hold after the database lookup is completed.
- C. Issue a Queue Step followed by the database lookup and a Resource Step.
- D. Issue a Queue Step followed by the database lookup and a Dequeue Step.

Answer: A

QUESTION 339:

If all n MTP transcoding sessions are utilized, and an n + 1 connection is attempted how will the next call be treated?

- A. The next call will complete without using the MTP transcoding resource

- B. The next call will not use an MTP and will use the transcoding resources associated with the codec to complete the call.
- C. The next call will use the alternate codec type and attempt to complete the call
- D. The next call will be redirected to the PSTN due to a lack of MTP resources.

Answer: A

QUESTION 340:

Which of the following is true about the 802.1q frame header?

- A. In Ethernet frame after the source address, 4 bytes 802.1Q header is included, which contains 16 bits for the tag protocol ID, 3 bits for the priority field, 1 bit for the canonical field (always 0), and 12 bits for the VLAN identifier.
- B. 802.1q frame is inserted inside the actual Ethernet frame. In other words, it is inserted after Source Address in the Ethernet frame. Size of 802.1q frame is 26 bytes.
- C. 802.1q frame is inserted at the beginning of Ethernet frame. Size of 802.1q frame is 4 bytes.
- D. In an Ethernet frame after the source address, 6 bytes 802.1Q header is included, which contains 32 bits for the tag protocol ID, 3 bits for the priority field, 1 bit for the canonical field (always 0), and 12 bits for the VLAN identifier.

Answer: A

QUESTION 341:

Which one of the following does NOT state Multicast Technologies Advantages?

- A. Bandwidth-conserving technology that reduces traffic by simultaneously delivering a single stream of information to thousands of corporate recipients and homes
- B. Prevent Denial of service (DoS) attacks in the networks
- C. Distributed Applications: makes multipoint applications possible
- D. Enhanced Efficiency: controls network traffic and reduces server and CPU loads
- E. Optimized Performance: eliminates traffic redundancy

Answer: B

QUESTION 342:

Which three of the following attributes would correctly describe MGCP? (Choose 3)

- A. Intelligent Endpoints
- B. Master/Slave
- C. Peer-to-Peer
- D. Call preservation on GW failover from one CCM server to another
- E. Uses a Proxy Server to communicate with Cisco CallManager

F. Centralized dial plan management

Answer: B,D,F

QUESTION 343:

Select 2 of the following which are NOT functions performed by MOH Audio Translator Service:

- A. Provides audio data from WAV files (ANN, MOH)
- B. Supports WMA and MP3.
- C. Adjusts volume levels of MOH source files
- D. Monitors a configured path for new files
- E. Converts new MOH source files to separate wav files for MOH codecs
- F. Provides TFTP client download of MOH files

Answer: A,F

QUESTION 344:

Identify the proper topology or the best way for deploying CAC in a centralized deployment:

- A. Use Cisco CallManager in a cluster at a centralized location and also at remote locations
- B. Use single Cisco CallManager at a centralized location to control all of the remote locations
- C. Use H.323 Gatekeeper at a centralized location and use CallManagers at remote locations
- D. Use CallManager at a centralized location and use H.323 Gatekeepers at remote locations

Answer: B

QUESTION 345:

If enabled, the RSVP for LLQ feature will assign what types of flows to the priority queue? (Choose 2)

- A. All traffic marked DSCP EF
- B. Voice flows generated from third-party applications, such as Microsoft NetMeeting
- C. All traffic marked CoS 5
- D. Voice flows generated from Cisco IOS applications
- E. All RSVP bandwidth requests

Answer: B,D

QUESTION 346:

You are implementing a CallManager solution utilizing MGCP gateways with PRI interface cards. After a firewall is turned up, your PRI is no longer working. What is most likely the issue?

- A. An L2TP tunnel needs to be set up between the CallManager and the firewall to carry signaling traffic
- B. CallManager TLS needs to be restarted after the firewall is installed to reestablish communication with the MGCP gateway.
- C. The CallManager server needs to be on the same contiguous subnet as the gateway without a firewall between them.
- D. The port range that the CallManager uses to communicate with the gateway is blocked.

Answer: D

QUESTION 347:

Which three of the following statements regarding implementing Unity in an existing Domino environment are correct? (Choose 2)

- A. Lotus Notes must be installed on the Unity server.
- B. The Unity server can service only one Domino domain.
- C. The DUC server component must be installed on the Unity server.
- D. The Domino server that Unity communicates with must be in the same Windows domain as Unity.

Answer: A,B

QUESTION 348:

Unity extensions will increase the Active Directory size by approximately what percent?

- A. 20
- B. 5
- C. 10
- D. 15

Answer: C

QUESTION 349:

Which of the following is NOT true about DHCP snooping?

350-030

- A. For DHCP snooping to function properly, all DHCP servers must be connected to the switch through trusted interfaces.
- B. DHCP snooping is a feature that provides network security by filtering untrusted DHCP messages and by building and maintaining a DHCP snooping binding database.
- C. DHCP Snooping has the capability to use rate limiting.
- D. DHCP Snooping stops Man-in-the-Middle (MITM) Attacks.
- E. DHCP Snooping is enabled by VLAN.

Answer: D

QUESTION 350:

Certkiller .com. is planning a deployment of Cisco IP Telephony using the Centralized Call Processing model. The company has 1 HQ and 25 branches in a hub and spoke configuration. The company policies determine that multicast traffic should not be carried over the WAN. Which of the following statements would not violate the company policies while successfully implementing Music on Hold throughout all the different sites? (Choose 3)

- A. Use MoH directly generated from the IP Phones in the Branches
- B. Use Multicast flows throughout the network, filtering Multicast flows in the WAN edge, and stream MoH streams from the flash of the branches' routers
- C. Use the AMOHB (Advanced Music on Hold for Branches) feature in Cisco CallManager
- D. Use Multicast flows in the HQ and Unicast flows in the branches
- E. Use Unicast MoH throughout the network

Answer: B,D,E

QUESTION 351:

Why has Cisco chosen to use the SCCP protocol in its IP telephony networks?

- A. It is an industry standard, open protocol.
- B. It uses intelligent endpoints.
- C. It is a peer to peer protocol.
- D. It enables the use of a rich set of features.

Answer: D

QUESTION 352:

On a Catalyst 3560, each port has a SCCP IP phone connected to it. PC's connected to the phone switch port do not have softphone nor Cisco VTTThe only legitimate traffic originating from the phone is:
should be dropped.

should be marked down to a DSCP Value of CS1
DSCP Value of CS1

- DSCP marking should be re-enforced.
- The Voice VLAN subnet is 10.0.1.0/24

What is the appropriate configuration for the catalyst 3560 to meet the requirements stated above?

```
A. policy-map IP-PHONE
class VOICE-BEARER
match access-group name VOICE
police 128000 8000 exceed-action drop
class VOICE-SIGNALING
match access-group name VOICE-SIGNALING
police 32000 8000 exceed-action police-dscp-transmit
class VOICE-ANY
match access-group name VOICE-ANY
police 32000 8000 exceed-action police-dscp-transmit
interface FastEthernet0/1
service-policy input IP-PHONE
ip access list extended VOICE-BEARER
permit udp 10.0.1.0.0.0.0.255 any range 16384 32767 dscp ef
ip access list extended VOICE-SIGNALING
permit tcp 10.0.1.0.0.0.0.255 any range 2000 dscp cs3
ip access list extended VOICE-ANY
permit ip 10.0.1.0.0.0.0.255 any
B. mls qos map policed-dscp 0 24 to 8
class-map match-all VOICE-BEARER
match access-group name VOICE
class-map match-all VOICE-SIGNALING
match access-group name VOICE-SIGNALING
class-map match-all VOICE-ANY
match access-group name VOICE-ANY
policy-map IP-PHONE
class VOICE-BEARER
set ip dscp EF
police 128000 8000 exceed-action drop
class VOICE-SIGNALING
set ip dscp CS3
police 32000 8000 exceed-action policed-dscp-transmit
class VOICE-ANY
set ip dscp BE
police 32000 8000 exceed-action policed-dscp-transmit
interface FastEthernet0/1
service-policy input IP-PHONE
ip access list extended VOICE-BEARER
permit udp 10.0.1.0.0.0.0.255 any range 16384 32767
```

```
ip access list extended VOICE-SIGNALING
permit tcp 10.0.1.0.0.0.255 any range 2000
ip access list extended VOICE-ANY
permit ip 10.0.1.0.0.0.255 any
C. mls qos map policed-dscp 0 24 to 8
class-map match-all VOICE-BEARER
match access-group name VOICE
class-map match-all VOICE-SIGNALING
match access-group name VOICE-SIGNALING
class-map match-all VOICE-ANY
match access-group name VOICE-ANY
policy-map IP-PHONE
class VOICE-BEARER
set ip dscp 46
police 128000 8000 exceed-action drop
class VOICE-SIGNALING
set ip dscp 24
police 32000 8000 exceed-action policed-dscp-transmit
class VOICE-ANY
set ip dscp 0
police 32000 8000 exceed-action policed-dscp-transmit
interface FastEthernet0/1
service-policy input IP-PHONE
ip access list extended VOICE-BEARER
permit udp 10.0.1.0.0.0.255 any range 16384 32767 dscp ef
ip access list extended VOICE-SIGNALING
permit tcp 10.0.1.0.0.0.255 any range 2000 dscp cs3
ip access list extended VOICE-ANY
permit ip 10.0.1.0.0.0.255 any
D. mis qos map policed-dscp 0 24 to 8
Class-map match-all VOICE-BEARER
match access-group name VOICE
Class-map match-all VOLCE-SIGNALING
match access-group name VOICE-SIGNALING
Class-map match-all VOICE-ANY
match access-group name VOICE-ANY
policy-map IP-PHONE
class VOICE-BEARER
set ip dscp CS1
police 128000 8000 exceed-action policed-dscp-transmit
class VOICE-SIGNALING
set ip dscp CS1
police 32000 8000 exceed-action policed-dscp-transmit
class VOICE-ANY
set ip dscp CS1
police 32000 8000 exceed-action policed-dscp-transmit
```

```
interface FastEthernet0/1
service-policy input IP-PHONE
ip access list extended VOICE-BEARED
permit udp 10.0.1.0.0.0.0.255 any range 16384 32767 dscp ef
ip access list extended VOICE-SIGNALING
permit tcp 10.0.1.0.0.0.0.255 any range 2000 dscp cs3
ip access list extended VOICE-ANY
permit ip 10.0.1.0.0.0.0.255 any
```

Answer: C

QUESTION 353:

A SIP endpoint can act as which of the following? (Choose 2)

- A. Back-to-back User Agent
- B. User Agent Server
- C. Call Agent
- D. User Agent Client

Answer: B,D

QUESTION 354:

Which two of the following attributes would correctly describe H.323? (Choose 2)

- A. Peer-to-Peer
- B. Centralized dial plan management
- C. Master/Slave
- D. Uses a Proxy Server to communicate with Cisco CallManager
- E. Intelligent Endpoints

Answer: A

QUESTION 355:

When implementing PRI backhaul for an MGCP gateway and CallManager, the Q.921 data-link protocol is terminated on what device?

- A. MGCP gateway
- B. CallManager
- C. Signaling Link Terminal
- D. The IP end device, such as an IP phone

Answer: A

QUESTION 356:

CallManager version 4.X Software conference bridges have the following characteristics:
(Choose 2)

- A. It supports G.711, G729 and Cisco Wideband conferences.
- B. All low bit-rate (LBR) calls must be transcoded prior to joining the conference call.
- C. A maximum of 64 participants in Ad Hoc conferences, or 128 in a Meet Me conference are supported.
- D. Separate transcoder resources are needed if calls using G711 codecs want to join a software conference bridge.

Answer: B,C

QUESTION 357:

An access-layer Cisco Catalyst 3550 is configured with voice and data VLANs. All QoS settings have been left at factory defaults, with two exceptions only:

1. **"mls qos trust device cisco-phone"** is applied to all access-edge ports
2. **"mls qos trust dscp"** is applied to all uplink-ports

Some access-edge ports are connected to Cisco IP Phones and other ports are directly connected to PCs. Assume that malicious users are setting the CoS and DSCP values of all their PC-generated packets to CoS 6 and EF, respectively. Assume that the IP Phones are administered by Cisco CallManager 4.0 (or higher).

What will be the DSCP settings of the (IP Phone-generated) Voice and Call-Signaling packets, as well as the (PC-generated) data packets as these packets exit the switch en route to the distribution layer?

- A. Voice: DSCP 40
Call-Signaling: DSCP 24
Data: DSCP 0
- B. Voice: DSCP 40
Call-Signaling: DSCP 24
Data: DSCP 48
- C. Voice: DSCP 46
Call-Signaling: DSCP 24
Data: DSCP 0
- D. Voice: DSCP 46
Call-Signaling: DSCP 24
Data: DSCP 46

Answer: D

QUESTION 358:

Which 2 functions are performed by a Route list?

- A. Points to a route list for routing
- B. Performs digit manipulation
- C. Points to the actual devices
- D. Matches dialed number for external calls
- E. Points to prioritized route groups
- F. Chooses path for call routing

Answer: E,F

QUESTION 359:

Which of the following does NOT accurately describe the Device Pool function in CM?

- A. The Device Pool allows to add Call Manager group to a device.
- B. The Device pool allows Failover preferences to a phone or gateway.
- C. The Device pool allows SRST Reference to a phone or gateway.
- D. The Device Pool allows Registration preferences to a phone or gateway.
- E. The Device pool allows Location preferences to a phone or gateway.

Answer: E

QUESTION 360:

How would a dependency record be used to delete a device pool?

- A. The dependency record searches only a specified database for a specified record that matches the search parameter and returns the location of that record in the database prior to deletion.
- B. The dependency record indicates which members of a device pool are subsets of other device pools so they can be moved easily.
- C. The dependency records show which records are associated with the record that you want to delete.
- D. The dependency record migrates the specified record to a new location prior to deletion to maintain database integrity.
- E. The dependency record searches for the specific record in a device pool so that the record can be migrated prior to deletion.

Answer: C

QUESTION 361:

When deploying IPMA in proxy mode, what is the minimum number of partitions and calling search spaces required?

- A. 3 partitions and 1 calling search space
- B. 2 partitions and 2 calling search spaces
- C. 1 partition and 4 calling search spaces
- D. 3 partitions and 2 calling search spaces
- E. 2 partitions and 3 calling search spaces

Answer: D

QUESTION 362:

Two ports on a 3600 gateway platform are stuck in the EMPARK state. What are two possible causes of this problem? (Choose 2)

- A. A fake answer has been configured on the router.
- B. The PSTN switch / PBX is sending a continuous off-hook signal.
- C. A call is parked and no one has answered.
- D. The DSP is having hardware or software issues.

Answer: B,D

QUESTION 363:

Network topology exhibit:

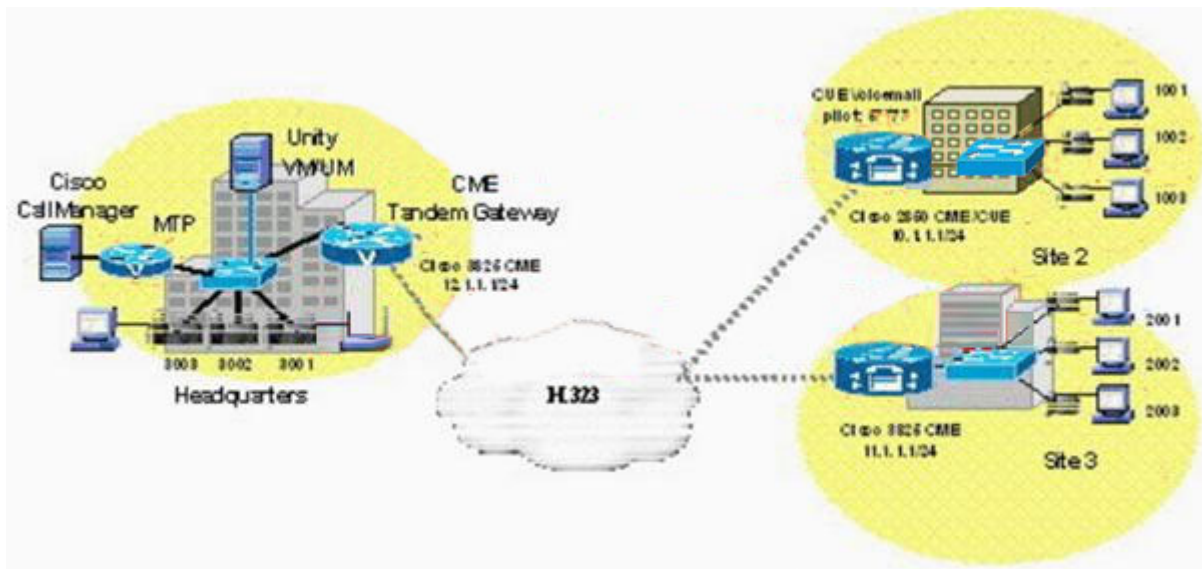

Configuration exhibit:

Cisco CME and Cisco UE (CUE) configured for voice call handling, voicemail, and auto-attendant capabilities in Site 2. Assume the following interfaces are configured for CME and CUE:

```
interface FastEthernet0/0
ip address 10.1.1.1 255.255.255.0
speed auto
half-doulex
!
interface Sertvice-Engine3/0
ip unnumbered FastEthernet0/0
service-module ip address 10.1.1.2 255.255.255.0
service-module ip default-gateway 10.1.1.1
...
telephony service
...
load 7960-7940 P00305000301
max-ephones 10
max-dn 40
ip source-address 10.1.1.1 port 2000
create cnf-files version-stamp 7960 Feb 25 2005
15:44:22
voicemail 57777
```

Consider the exhibits. Certkiller .com has added two remote sites (site 2 and site 3) with a Cisco CME running per each site. Each remote site has its own voicemail solution using CUE(see Site 2 for details), however, Site 2 needs to be integrated with the Cisco CallManager deployed in headquarters to allow calls between CCM phones 3xxx at Headquarters and CME at remote sites (1xxx and 2xxx). What additional configuration commands are needed for CME/CUE integration?

A. Configure the following on CME system to route the calls to the CUE module and voicemail pilot#57777:

```
Ip route 10.1.1.2 255.255.255.255 10.1.1.1
Dial-peer voice 57777 voip
Destination-pattern 57777
Session protocol sipv2
Session target ipv4:10.1.1.2
Dtmf-relay sip-notify
codec g711ulaw
no vad
```

B. Configure the following on CME system to route the calls to the CUE module and voicemail pilot#57777:

```
ip route 10.1.1.2 255.255.255.255 Service-Engine3/0
dial-peer voice 57777 voip
destination-pattern 57777
session protocol sipv2
session target ipv4:10.1.1.2
dtmf-relay sip-notify
codec g711ulaw
no vad
```

C. Configure the following on CME system to route the calls to the CUE module and voicemail pilot#57777:

```
Ip route 10.1.1.2 255.255.255.255 10.1.1.1
dial-peer voice 5777 voip
destination-pattern 57777
session target ipv4:10.1.1.2
codec g711ulaw
no vad
```

D. Configure the following on CME system to route the calls to the CUE module and voicemail pilot#57777:

```
Ip route 10.1.1.2 255.255.255 Service-Engine3/0
dial-peer voice 5777 voip
destination-pattern 57777
session target ipv4:10.1.1.2
codec g711ulaw
no vad
```

Answer: B

QUESTION 364:

Which two ways are customized phone services subscribed to? (Choose 2)

- A. The CallManager administrator uses the Cisco IP Phone Services Configuration menu to define and maintain the list of Cisco IP Phone services to which users can subscribe at their site.
- B. Users can log into the Cisco CallManager User Options Menu and select the services they want to subscribe to and CallManager will automatically configure those services.
- C. The CallManager administrator uses the Cisco IP Telephony Services Configuration menu to develop separate lists of users and services.
- D. The CallManager administrator can add services to Cisco IP phones and device profiles.
- E. Users can log into the Cisco CallManager User Options Menu to subscribe to services already configured by the CallManager administrator.

Answer: D,E

QUESTION 365:

Which statement does NOT describe dialing domain functionality in Cisco Unity?

- A. Dialing domains are multiple Unity servers that are handling subscribers that are on a single switch or networked switch
- B. Dialing domain IDs are stored on the primary location object. Multiple primary location objects with the same value for this ID make up a dialing domain.
- C. All delivery locations get the same dialing domain ID as the primary location of the

box they are created on.

D. Dialing domains are also necessary if the Unity servers involved don't have overlapping dial plans.

E. All users in the dialing domain should be able to pick up their phones and dial each other directly without having to dial trunk access codes or use outside lines.

Answer: D

QUESTION 366:

Calculate the percentage of overall bandwidth saved (at Layer 2) by cRTP for a G.729 VoIP call packetized at 50 pps running over a MLP link.

- A. Approximately 20%
- B. Approximately 60%
- C. Approximately 30%
- D. Approximately 50%
- E. Approximately 40%

Answer: D

QUESTION 367:

Certkiller .com is planning a deployment of Cisco Contact Center Express and are looking for a design that provides maximum resilience, performance, and redundancy. They are planning to install Cisco CallManager 4.1(3) and Cisco Contact Center Express 4.0. How many CTI Managers can we configure in one cluster?

- A. 1
- B. 16
- C. 8
- D. 4
- E. 2

Answer: C

QUESTION 368:

What is the primary difference between 2 byte cRTP packet and the 4 byte cRTP packet?

- A. The 4 byte cRTP packet contains an additional field containing the full destination IP address.
- B. The 4 byte header is used for RTP packets that have a larger payload (i.e 30 msec samples vs 10 msec samples).
- C. The 4 byte cRTP packet contains an additional field containing the full source IP address.

- D. The 4 byte header has 2 bytes of padding in order to align the packet.
- E. The 4 byte cRTP packet contains a UDP Checksum.

Answer: E

QUESTION 369:

Which one of the following type of SIP responses would indicate that a server encountered an error in attempting to complete a SIP request?

- A. 1xx
- B. 6xx
- C. 5xx
- D. 3xx
- E. 4xx

Answer: C

QUESTION 370:

When is an RFC 2833 compliant MTP resource required?

- A. When CallManager makes an SCCP call
- B. When CallManager makes an inter-cluster trunk call to another CallManager cluster using H.323
- C. When MTP service is configured to support both conferencing and transcoding on the same DSP
- D. When there is a need for an MTP device to monitor for payload type and act as a translator between in-band and out-of-band payload types
- E. When an MTP needs to provide supplementary services to an H.323v2 call

Answer: D

QUESTION 371:

The IOS command "call rsvp-sync resv-timer 10" is used to set the timer on the:

- A. Originating and terminating VoIP gateway for completing RSVP reservation setups within 10 seconds
- B. Terminating VoIP gateway for completing RSVP reservation setups within 10 seconds
- C. VoIP gatekeeper for completing RSVP reservation setups within 10 seconds
- D. Originating VoIP gateway for completing RSVP reservation setups within 10 seconds

Answer: B

QUESTION 372:

Certkiller .com would like to provide marketing messages when callers are placed on hold. Each department in the company needs to have a specific MoH message for their callers. There are 12 departments in the company. Eleven of the departments are sales oriented and need to market to customers with MOH. The 12th department is administration and will require specific messages for each group within that department. How should the MoH services be configured for this company?

- A. Use unicast to stream the MoH files for the sales departments and multicast for a single stream for administration.
- B. Use multicast to stream a different message to each sales department caller and unicast to each caller for each administrative group.
- C. Use unicast to stream the MoH files for the sales departments and administration.
- D. Use multicast to stream one message to each caller for all the sales departments and unicast to stream a different set of messages to each caller for each administrative group.
- E. Use multicast to stream the MoH files for the sales departments and multicast for a single stream for administration.

Answer: B

QUESTION 373:

A single Unity server is being deployed to provide voicemail for multiple CallManager Express systems. One CallManager Express is colocated with the Unity server and the rest are connected via a WAN. Which of the following best describes how to configure the remote CallManager Express systems so calls can be forwarded to the central Unity server?

- A. Each remote CallManager Express is configured with ephones which register with dedicated ports in the Unity server.
- B. The remote CallManager Express systems are configured with a VoIP dial peer that directs calls to the Unity pilot number to the central CallManager Express.
- C. Each remote CallManager Express is configured with a VoIP dial peer for each port assigned to it in Unity.
- D. Each remote CallManager Express system is defined as a CallManager cluster in the Unity server.

Answer: B

QUESTION 374:

Which 2 are NOT functions performed by Cisco Media Streaming App Service?

- A. Supports DB change notification processing
- B. Provides SDI trace, event logs, and Perfmon counters

350-030

- C. Provides SCCP stack for 4 software devices: ANN, CFB, MOH, and MTP
- D. Adjusts volume levels of MOH source files
- E. Provides audio data from WAV files: ANN, MOH
- F. Converts new MOH source files to separate WAV files for MOH codecs

Answer: D,F